

# Rhum Field

## Rhum Production Increase Environmental Statement

RHM55MS700001

Revision	Issue Purpose	Prepared By	Reviewed By	Approved by
1		[Signature]	[Signature]	[Signature]

This document is uncontrolled when printed or saved locally



## Revision summary

Section/page	Date	Description of change
N/A	N/A	N/A

## Description of change

Rev number	Description of change	Date
1	Issued for use	27/05/2021

## Distribution

<b>Name</b>	<b>Title</b>	<b>Location</b>
[Insert name]	Insert Job Title	Insert Location
[Insert name]	Insert Job Title	Insert Location
[Insert name]	Insert Job Title	Insert Location
[Insert name]	Insert Job Title	Insert Location

## Contents

<b>Revision summary</b>	<b>2</b>
<b>Description of change</b>	<b>2</b>
<b>Distribution</b>	<b>3</b>
<b>Contents</b>	<b>4</b>
<b>List of abbreviations</b>	<b>7</b>
<b>List of references</b>	<b>10</b>
<b>Environmental Statement Details</b>	<b>12</b>
Section A: Administrative Information	12
A1 - Project Reference Number	12
A2 - Applicant Contact Details	12
A3 - ES Contact Details (if different from above)	12
A4 – ES Preparation	12
A5 – Licence Details	12
Section B: Project Information	13
B1 – Nature of Project	13
B2 – Project Location	13
B3 – Previous Applications	13
<b>1. Introduction</b>	<b>14</b>
<b>2 Scope of Environmental Statement</b>	<b>14</b>
<b>3 Serica’s Environmental Management System</b>	<b>17</b>
3.1 Major Accident Prevention Policy	17
<b>4 Project Description</b>	<b>17</b>
4.1 Production profiles	18
<b>5 Production Facility</b>	<b>20</b>
5.1 Process overview	20
5.2 Produced water.	20
5.3 Flaring	21
5.4 Venting	21
5.5 Drains	22
5.6 Combustion equipment	23
<b>6 Environmental Baseline</b>	<b>24</b>
6.1 Data sources	24
6.2 Weather and Sea Conditions	24
6.3 Air Quality and Climate	25
6.4 Seabed sediment	27
6.5 Benthic communities	28
6.6 Plankton	29
6.7 Fish and shellfish	30

This document is uncontrolled when printed or saved locally

6.8	Marine mammals	31
6.8.1	Cetaceans	31
6.8.2	Pinnipeds	32
6.9	Seabirds	32
<b>7</b>	<b>Conservation Areas</b>	<b>33</b>
7.1	Annex 1 Habitats	33
7.2	Annex II Species and European Protected Species	33
7.3	Marine protected areas	34
7.4	Social and Economic Environment	34
7.4.1	Fishing effort	34
7.4.2	Oil and gas activities	35
7.4.3	Shipping	35
7.4.4	Other activities	36
<b>8</b>	<b>Assessment of Potential Impacts from Planned Activities</b>	<b>36</b>
8.1	Screening process	36
8.2	Atmospheric emissions	37
8.3	Discharges to sea	39
8.3.1	Chemical discharges	39
8.3.2	Hydrocarbon discharges	39
8.4	Accidental releases	40
8.5	Biodiversity	43
8.5.1	Plankton & Benthos	43
8.5.2	Fish	43
8.5.3	Seabirds	43
8.5.4	Marine mammals	43
8.5.5	Protected sites and species	43
8.5.6	Other sea users	43
8.6	Transboundary impacts	44
<b>9</b>	<b>National Marine Plan</b>	<b>44</b>
9.1	GEN 1 – General planning and principle	44
9.2	GEN 4 – Co-existence	44
9.3	GEN 5 – Climate change	44
9.4	GEN 9 – Natural heritage	44
9.5	GEN 12 – Water quality and resource	45
9.6	GEN 13 – Noise	45
9.7	GEN 14 – Air quality	45
9.8	GEN 21 – Cumulative impacts	45
<b>10</b>	<b>Permits, licences and consents to be updated</b>	<b>45</b>
10.1	Production Consent	45

10.2	Chemical Permit _____	45
10.3	Oil Discharge Permit _____	46
10.4	Pollution Prevention and Controls Permit _____	46
10.5	Flare and Vent Consents _____	46
<b>11</b>	<b>Conclusion</b> _____	<b>46</b>
	<b>APPENDIX A – Non-Technical Summary</b> _____	<b>48</b>
	<b>Introduction and Description</b> _____	<b>48</b>
	Physical Environment _____	51
	Biological Environment _____	52
	Protected areas and species _____	52
	<b>Human Environment (Other Users)</b> _____	<b>53</b>
	<b>Assessment</b> _____	<b>53</b>
	Atmospheric Emissions _____	54
	Discharges to sea _____	54
	Accidental Releases _____	55
	<b>Conclusion</b> _____	<b>55</b>

## List of abbreviations

Abbreviation	Definition
°C	Degrees Celsius
°F	Degrees Fahrenheit
ALARP	As Low as Is Reasonably Practicable
BEIS	Department for Business, Energy & Industrial Strategy
CETCO	CETCO Energy Services
CH <sub>4</sub>	Methane
CMAPP	Corporate Major Accident Prevention Policy
CO	Carbon Monoxide
CO <sub>2</sub>	Carbon Dioxide
DHSV	Downhole Safety Valve
DTI	Department of Trade & Industry
EPS	European Protected Species
ERT	Environment and Resource Technology
ES	Environmental Statement
ESD	Emergency Shutdown
FPS	Forties Pipeline System
HP	High Pressure
HPHT	High Pressure, High Temperature
ICES	International Council for the Exploration of the Sea
in	Inches
IUCN	International Union for Conservation of Nature
km	Kilometres
LP	Low Pressure
LPBC	Low Pressure Booster Compressor
m	Meters
m/s	Meters per Second

m <sup>3</sup>	Meters Cubed
m <sup>3</sup> /day	Meters Cubed per Day
MAFF	Ministry of Agriculture, Fisheries and Food
mg/l	Milligrams per Litre
MOL	Main Oil Line
MP	Medium Pressure
N <sub>2</sub> O	Nitrous oxide
NCMPA	Nature Conservation Marine Protected Areas
NMP	National Marine Plan
NMPI	National Marine Plan interactive
NNS	Northern North Sea
NO <sub>x</sub>	Nitrogen Oxide
O&GUK	Oil and Gas UK
OGA	Oil and Gas Authority
OMS	Operations Management System
OPEP	Oil Pollution Emergency Plans
OPPC	Oil Pollution Prevention and Control
PPC	Pollution Prevention and Controls Permit
psi	Pounds per Square Inch
PUQ	Process, Utilities and Quarters
PW	Produced Water
ROV	Remotely Operated Vehicle
SAC	Special Areas of Conservation
SCI	Sites of Community Importance
sm <sup>3</sup>	Standard Cubic Meter
SMRU	Sea Mammal Research Unit
SO <sub>2</sub>	Sulphur Dioxide
SPA	Special Protection Areas



UCM	Unresolved Complex Mixture
UKCS	UK Continental Shelf
UKDMAP	United Kingdom Digital Marine Atlas
UKOOA	United Kingdom Offshore Operators Association
VOCs	Volatile Organic Compounds
WAD	Western Area Development

## List of references

- 1 Aires, C., González-Irusta, J.M., Watret, R. 2014. Updating Fisheries Sensitivity Maps in British Waters. Scottish Marine and Freshwater Science Vol 5(10). Edinburgh: Scottish Government, 88pp. DOI: 10.7489/1555-1.
- 2 Basford, D J. and Eleftheriou, A. (1988) "The benthic environment of the North Sea (560 to 610). Journal of the Marine Biological Association. Vol. 68, pp.125-141.
- 3 Basford, D.J., Eleftheriou, A., Davies, I.M., Irion, G., and Soltwedel, T. (1993) "The ICES North Sea Benthos Survey: The Sedimentary Environment". ICES Journal of Marine Science. Vol.50, pp. 71-80.
- 4 BEIS (2020). 2019 UK greenhouse gas emissions, final figures, 42pp. [https://assets.publishing.service.gov.uk/government/uploads/system/uploads/attachment\\_data/file/957887/2019\\_Final\\_greenhouse\\_gas\\_emissions\\_statistical\\_release.pdf](https://assets.publishing.service.gov.uk/government/uploads/system/uploads/attachment_data/file/957887/2019_Final_greenhouse_gas_emissions_statistical_release.pdf)
- 5 BMT Cordah. (1998). UKCS 18th Round Environmental Screening Report: Area 1 Northern North Sea. Report to UKOOA. CORDAH, eyland, Pembrokeshire. Report No. OPRU/4/98.
- 6 BEIS (Department for Business, Energy & Industrial Strategy). (2020). BEIS (OPRED): The Offshore Petroleum Production and Pipelines (Assessment of Environmental Effects) Regulations 1999 (as amended) - A Guide, December 2020.
- 7 Climate Change Committee website. <https://www.theccc.org.uk/> [accessed April 2021].
- 8 Coull, K.A., Johnstone, R. and Rogers, S.I. (1998). Fisheries Sensitivity Maps in British Waters. UKOOA Ltd.
- 9 DECC (Department of Energy and Climate Change). (2016). Strategic Environmental assessment. Offshore Energy SEA Environmental report. Available online at: <https://www.gov.uk/guidance/offshore-energy-strategic-environmental-assessment-sea-an-overview-of-the-sea-process#offshore-energy-sea-the-current-sea>
- 10 DEFRA (2019). Clean Air Strategy 2019 [accessed April 2021].
- 10.1 [https://assets.publishing.service.gov.uk/government/uploads/system/uploads/attachment\\_data/file/770715/clean-air-strategy-2019.pdf](https://assets.publishing.service.gov.uk/government/uploads/system/uploads/attachment_data/file/770715/clean-air-strategy-2019.pdf)
- 11 DTI (Department of Trade & Industry). (2004). Strategic Environmental Assessment of the parts of the northern and central North Sea to the east of the Scottish mainland, Orkney and Shetland. SEA 5, May 2004.
- 12 Ellis, J.R., Milligan, S., Readdy, L., South, A., Taylor, N. and Brown, M. (2012). Mapping the spawning and nursery grounds of selected fish for spatial planning. Report to the Department of Environment, Food and Rural Affairs from Cefas. Defra Contract No. MB5301.
- 13 ERT (Environment and Resource Technology). (2001). BP Bruce (UKCS Blocks 9/8a, 9/9a and 9/9b) Seabed Environmental Survey, September 2001: Final Report ERT 610/R003/Bruce.
- 14 Fugro. (2017). Northern North Sea ROV Analysis, Bruce Field (Fugro Document No. 160620\_02Rev2).
- 15 Gardline Surveys. (2012). Bruce Environmental Baseline Project Ref:8864. (Rev 05) 20110921.
- 16 Global Marine Research. (2014). Rhum Manifold ROV Survey.
- 17 IUCN (International Union for Conservation of Nature). (2021). The IUCN Red List of Threatened Species. Available online at: <http://www.iucnredlist.org> [Date accessed: April 2021].
- 18 JNCC (Joint Nature Conservation Committee). (2019). Seabird Oil Sensitivity Index. Available online at: <https://jncc.gov.uk/our-work/seabird-oil-sensitivity-index-sosi/> [Date accessed: April 2021].

- 19 Johnson, H., Richards, P.C., Long, D. and Graham, C.C. (1993). The geology of the northern North Sea. BGS United Kingdom Offshore Regional Report.
- 20 Jones, J., McConnell B., Sparling, C., and Matthiopoulos J. (2013). Marine Mammal Scientific Support Research Programme MMSS/001/11 Grey and harbour seal density maps, Sea Mammal Research Unit Report to Scottish Government. Version 1500.
- 21 Kober, K., Webb, A., Win, I., Lewis, M., O'Brien, S., Wilson, L.J. & Reid, J.B. 2010. An analysis of the numbers and distribution of seabirds within the British Fishery Limit aimed at identifying areas that qualify as possible marine SPAs, JNCC Report No. 431. JNCC, Peterborough, ISSN 0963-8091.
- 22 Künitzer, A., Basford, D., Craeymeersch, J.A., Dewarumez, J.M., Dörjes, J., Duineveld, C.A., Elftheriou, A., Heip, C., Herman, P., Kingston, P., Niermann, U., Rachor, E., Rumohr, H., and de Wilde, P.A.J. (1992) "The Benthic Infauna of the North Sea: Species Distribution and Assemblages". ICES Journal of Marine Science. Vol. 49.
- 23 MAFF (Ministry of Agriculture, Fisheries and Food). (1981). Atlas of the Seas Around the British Isles. Directorate of Fisheries Research.
- 24 Marine Scotland. (2020) 2019 Scottish Sea Fisheries Statistics - Fishing Effort and Quantity and Value of Landings by ICES Rectangles. DOI: 10.7489/12338-1. Available online at: <https://data.marine.gov.scot/dataset/2019-scottish-sea-fisheries-statistics-fishing-effort-and-quantity-and-value-landings-ices> [Date Accessed: April 2021]
- 25 Mazik, K., Strong, J., Little, S., Bhatia, N., Mander, L., Barnard, S. and Elliott, M. (2015). A review of the recovery potential and influencing factors of relevance to the management of habitats and species within Marine Protected Areas around Scotland. Scottish Natural Heritage Report No. 771 [online]. Available at: [http://www.snh.org.uk/pdfs/publications/commissioned\\_reports/771.pdf](http://www.snh.org.uk/pdfs/publications/commissioned_reports/771.pdf)
- 26 NMPi (National Marine Plan interactive). (2021). The Scottish Government National Marine Plan Interactive. Available at: <https://marinescotland.atkinsgeospatial.com/nmpi/> [Date accessed: April 2021].
- 27 OGA (Oil & Gas Authority). (2016). Information on levels of shipping activity. Available online at: [https://www.ogauthority.co.uk/media/1419/29r\\_shipping\\_density\\_table.pdf](https://www.ogauthority.co.uk/media/1419/29r_shipping_density_table.pdf) [date accessed: April 2021].
- 28 Reid, J.B., Evans, P.G.H. and Northridge, S.P. (Eds.) (2003). Atlas of Cetacean Distribution in North-west European Waters. JNCC, Peterborough.
- 29 Scottish Government. (2018). Fishing Effort and Quantity and Value of Landings by ICES Rectangle. Internet: <http://www.gov.scot/Topics/Statistics/Browse/Agriculture-Fisheries/RectangleData>. Accessed October 2018.
- 30 SCOS. (2013). Scientific advice on matters related to the management of seal populations: 2013, Special Committee on Seals. Available online at <http://www.smru.st-andrews.ac.uk/pageset.aspx?psr=411>
- 31 SMRU (Sea Mammal Research Unit). (2001). Background Information on Marine Mammals Relevant to SEA2. Technical Report produced for Strategic Environmental Assessment – SEA2. Technical Report TR\_006.
- 32 Svendsen, E., Sætre, R. and Mork, M. (1991) Features of the northern North Sea circulation. Continental Shelf Research. Vol. 11, Issue 5, pp. 493-508.
- 33 UKDMAP (United Kingdom Digital Marine Atlas). (1998). Version 3.00. Includes supplementary Seabirds and Cetaceans software compiled by JNCC, Aberdeen.
- 34 UKOOA (United Kingdom Offshore Operators Association). (2000). UK Benthos: database of offshore environmental benthic surveys in the UK sector of the North Sea. UKOOA, Aberdeen.

## Environmental Statement Details

### Section A: Administrative Information

#### A1 - Project Reference Number

D/4267/2021

#### A2 - Applicant Contact Details

[REDACTED]

Serica Energy, H1 Building Hill of Rubislaw, Anderson Drive, Aberdeen, AB15 6BY

#### A3 - ES Contact Details (if different from above)

As above

#### A4 – ES Preparation

Name	Title	Company	Relevant Qualification / Experience
[REDACTED]	Serica Energy	Environmental and Compliance Advisor	[REDACTED]
[REDACTED]	Senior Consultant	BMT	[REDACTED]
[REDACTED]	Graduate Consultant	BMT	[REDACTED]
[REDACTED]	BMT Associate	BMT	[REDACTED]

#### A5 – Licence Details

<b>Licence Number:</b>	
<b>Licensee</b>	<b>Percentage Equity</b>
Serica Energy	50%
National Iranian Oil Company (NIOC)	50%

## Section B: Project Information

### B1 – Nature of Project

The Rhum R3 well is an existing well which is being brought online, having been drilled in 2005 and shut in for 16 years. As a result of the ongoing well intervention and inclusion of the hydrocarbons from Rhum R3, it is anticipated that gas production from the Rhum Field will increase by an amount that exceeds 500,000 m<sup>3</sup> per day. In support of an application for an increase in the production consent, this Environmental Statement (ES) has been prepared.

### B2 – Project Location

Hydrocarbons from the Rhum field produce back to the Bruce Platform, and this is where impacts are likely to occur. Impacts associated with the well intervention works have been assessed in a separate MAT application (WIA/925). The location of the Bruce is defined below:

- Quadrant number(s): 3
- Block number(s): 29a
- Latitude: 59° 44' 34" North
- Longitude: 01° 40' 22" East
- Distance from the nearest points of land from the Bruce Platform.

Location	Distance (km)	Bearing (Degrees)
Isle of Noss	156	287
Fair Isle	187	264
Norwegian mainland (Bergen)	192	072
Duncansby Head	295	248

- Distance from the Bruce Platform to nearest international median line (km): 17 km (UK Norwegian)

### B3 – Previous Applications

In 2002 an Environmental Statement was submitted for the Rhum Field Development. The Project Reference number was D/1638/2002. The Project name being the "Rhum Field Development" and the Project Operator was BP Exploration Operating Company Ltd.

## 1. Introduction

Serica Energy (UK) Limited (Serica) plan to workover the Rhum R3 3/29a-6 production well which was drilled as a high pressure, high temperature (HPHT) well by BP in 2005.

The well forms part of the Rhum field development which consists of three subsea wells tied into a central manifold that produces back to the Serica operated Bruce Platform. The Rhum field is located in the northern North Sea (NNS) in block 3/29a, 400 km north east of Aberdeen and 44 km north of the Bruce Process, Utilities and Quarters (PUQ) platform (Figure 1) and is part of the wider Bruce, Keith and Rhum (BKR) area.

After drilling the Rhum R3 well operational issues were encountered during the completion phase which led to hydrates forming in the completion tubing and annulus. Consequently, the well was suspended and has not produced to date. A workover was conducted in October 2005 in an attempt to recover the well and bring it online. However, further complications occurred, and this resulted in a fish (slickline tool string and wire) being left in the hole above the downhole safety valve.

The Rhum R3 well was drilled as an HPHT with a reservoir pressure of 12,418 psi and temperature of 298°F (147.8°C). However, production of the Rhum field from the two other subsea wells has depleted the reservoir pressure to 6,791 psi, significantly below the high-pressure classification. For the planned workover campaign, the well has been classified as an HPHT well for the initial stages of the programme due to the potential risk of encountering hydrocarbons at virgin pressure trapped within the hydrates. Once the hydrates have been dissociated and the pressure classification of the well has been confirmed, it is expected to be downgraded to sub 10,000 psi.

As a result of the ongoing well intervention and inclusion of the hydrocarbons from Rhum R3, it is anticipated that production from the Rhum field will increase in excess of 500,000 m<sup>3</sup> of gas per day. In support of an application for an increase in the production consent, this Environmental Statement (ES) has been prepared.

The Rhum field development was subject to an environmental impact assessment, the results of which were presented in an Environmental Statement in 2002 (under project reference number D/1638/2002). Production volumes from the Rhum field were originally assessed to average 8.5 m<sup>3</sup> per day for the 16 years following first gas with an estimated peak rate of 10.2 m<sup>3</sup> per day. The flowing of the third Rhum well (R3) will result in an increase from current production volumes, but these would not exceed the estimates originally assessed in the 2002 ES.

The Rhum R3 well is expected to be brought online in Q3 2021.

## 2 Scope of Environmental Statement

Serica Energy are seeking to increase production at the Rhum field by conducting workover operations on the Rhum 3 well. The Rhum field currently holds the following Petroleum Production Licences; P198, P566, P975. The current Long Term Production consent was granted to Serica Energy on 1st January 2018 and in its current form is due to expire on the 31st of December 2023. In line with The Offshore Oil and Gas Exploration, Production, Unloading and Storage (Environmental Impact Assessment) Regulations 2020 – A Guide (BEIS, 2020), the production increase has been averaged over a period of 3 years (the length

of consent being applied for), the averaged production increase and see daily averaged gas production figures from the Rhum Field being more than 500,000 m<sup>3</sup> above the current baseline value consented for 2021. The current production licence for the Rhum field does not cover the assessed increase in production and subsequently an ES is being submitted in support of the production increase.

This ES focusses on the potential impacts this increase in production may have on the environment, particularly the environment surrounding the Bruce platform through which the Rhum production will flow through. As per the Regulatory Guidance this ES is a “slim-line” ES with a reduced environmental base line section and focussing solely on the potential impacts associated with increased production and not with those related to the workover operation itself. Those impacts have already been assessed in alignment with the necessary permitting and licencing requirements of Department for Business, Energy, and Industrial Strategy (BEIS). A screening of the potential impacts from the increase from the Rhum R3 well identified that emissions to air, oil and chemical discharges to sea, and chemical usage during the production process were a potential risk to the environment.

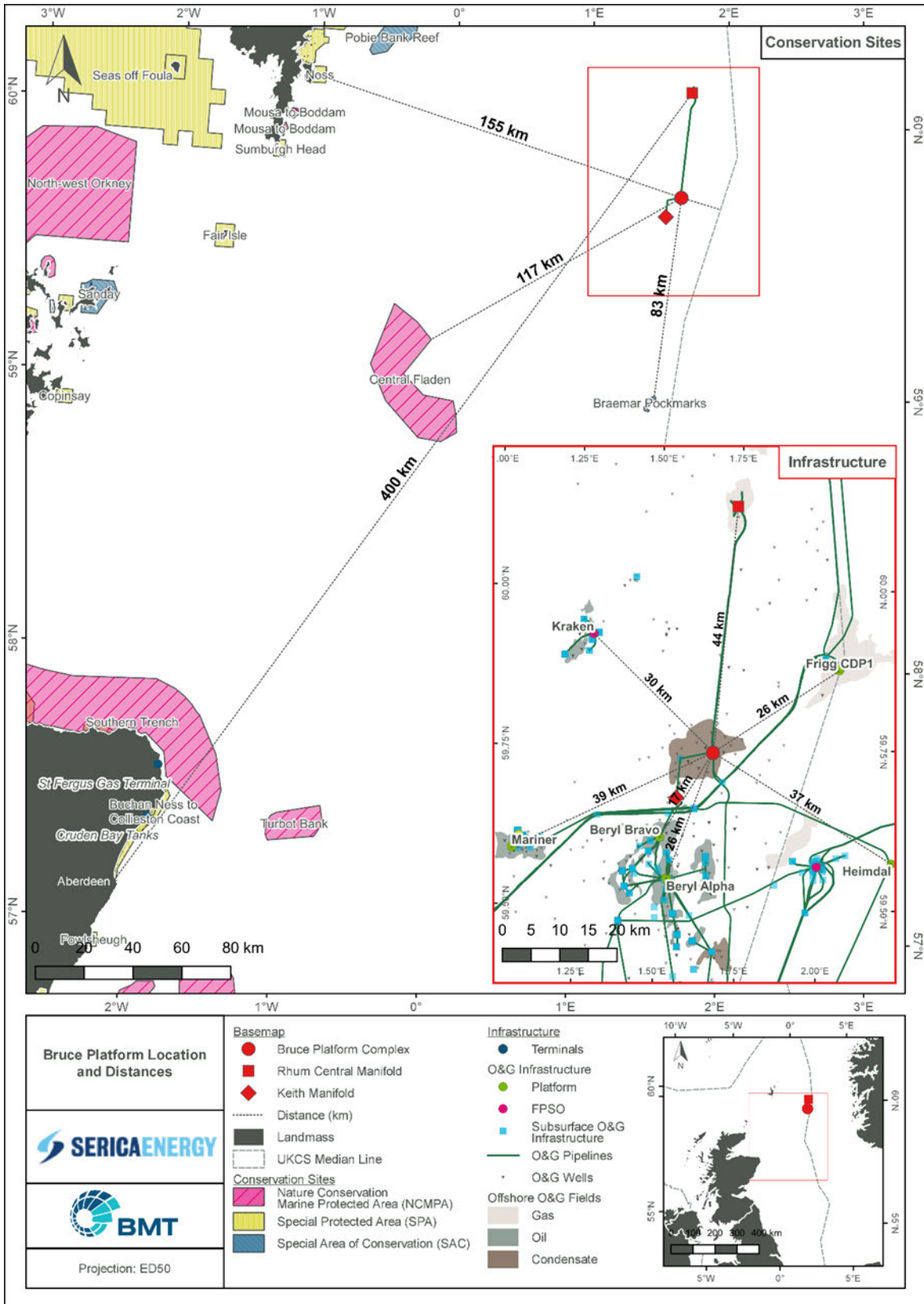

Figure 1 – Bruce, Keith and Rhum (BKR) Location Map



### 3 Serica’s Environmental Management System

The identification, control and mitigation of environmental impacts associated with all of Serica’s activities form an integral part of managing the business. Potential impacts are identified during the planning stages of all operations, and the risks evaluated and managed through an integrated Operations Management System (OMS). This system provides the structured management framework within which environmental impacts are identified, assessed, controlled, and monitored.



Figure 2 - Serica's Operational Management System

The Serica OMS is the mechanism that ensures the company standards are maintained, that the commitments specified in this ES are met and that any unforeseen aspects of operations are detected. This structured management approach will be used to ensure that the on-going process of identification, assessment and control of environmental risks will continue throughout planning and operations.

#### 3.1 Major Accident Prevention Policy

Serica recognises that the nature of oil and gas activities may give rise to major accident hazards and that they have obligations to all stakeholders to reduce the risks associated with such hazards to levels as low as is reasonably practicable (ALARP). In order to meet these obligations, Serica has developed a Corporate Major Accident Prevention Policy (CMAPP) which is supported by the OMS. The CMAPP provides demonstration from the Board of Serica of their commitment to major accident prevention.

### 4 Project Description

The Rhum field is in Production and the Rhum 3 well has already been drilled. Consequently, this ES only covers the increase in production from the Rhum field; all well intervention works

associated with the field have been assessed and permitted under Well Intervention Application WIA/1037. The proposed project includes a workover of the Rhum R3 3/29a-6 production well to maintain and increase current production levels on the Rhum field. When R3 is brought online it will feed back condensate and gas to the Rhum central manifold that is tied back to the Bruce platform (59° 44' 34" North; 01° 40' 22" East). Located in the NNS in block 3/29 the associated subsea infrastructure includes the Rhum manifold, 16" Production Pipeline (PLA 2091), IMS Line (PLA-2092) and umbilical (PLU 2099). This section provides details on the anticipated increase to production from the Rhum field.

The Rhum field currently holds the following Petroleum Production Licences; P198, P566, P975. The current Long Term Production consent was granted to Serica Energy on 1<sup>st</sup> January 2018 and in its current form is due to expire on the 31<sup>st</sup> December 2023. The current Rhum field permit assesses the following production volumes (Table 1):

Table 4-1 - Current Production Volumes (Source Rhum Production Consent)

Year	Min Oil (000 m <sup>3</sup> per day)	Min Oil (tonnes per day)	Min Gas (000 m <sup>3</sup> per day)	Max Oil (000 m <sup>3</sup> per day)	Max Oil (tonnes per day)	Max Gas (000 m <sup>3</sup> per day)
2019	0.08	57.0	2200	0.21	149.5	5959
2020	0.08	57.0	2200	0.18	128.1	5235
2021	0.08	57.0	2000	0.17	121.0	4789
2022	0.07	49.9	1800	0.14	99.7	4118
2023	0.05	35.6	1500	0.12	85.4	3441

#### 4.1 Production profiles

The production profile for the proposed increase from the Rhum field between 2021 and 2023 with the inclusion of the R3 3/29a-6 well is illustrated for the Rhum field in Figure 3. Post 2023 daily gas production volumes will fall below the 500,000 m<sup>3</sup> daily increase threshold returning to an assessed 4,865,000 m<sup>3</sup> per day, an increase of 76,000 m<sup>3</sup> on 2021 baseline maximum production estimates.

In line with The Offshore Oil and Gas Exploration, Production, Unloading and Storage (Environmental Impact Assessment) Regulations 2020 guidance document the estimated maximum increase in production has been averaged over a three-year period (2021-2023). The daily increase in Rhum field production will be in excess of 500,000 m<sup>3</sup> above the current consented production volume until 2024 with an average increase in annual production from the Rhum field assessed to be in the region of 2,091,000 m<sup>3</sup> per day (Table 4-2).

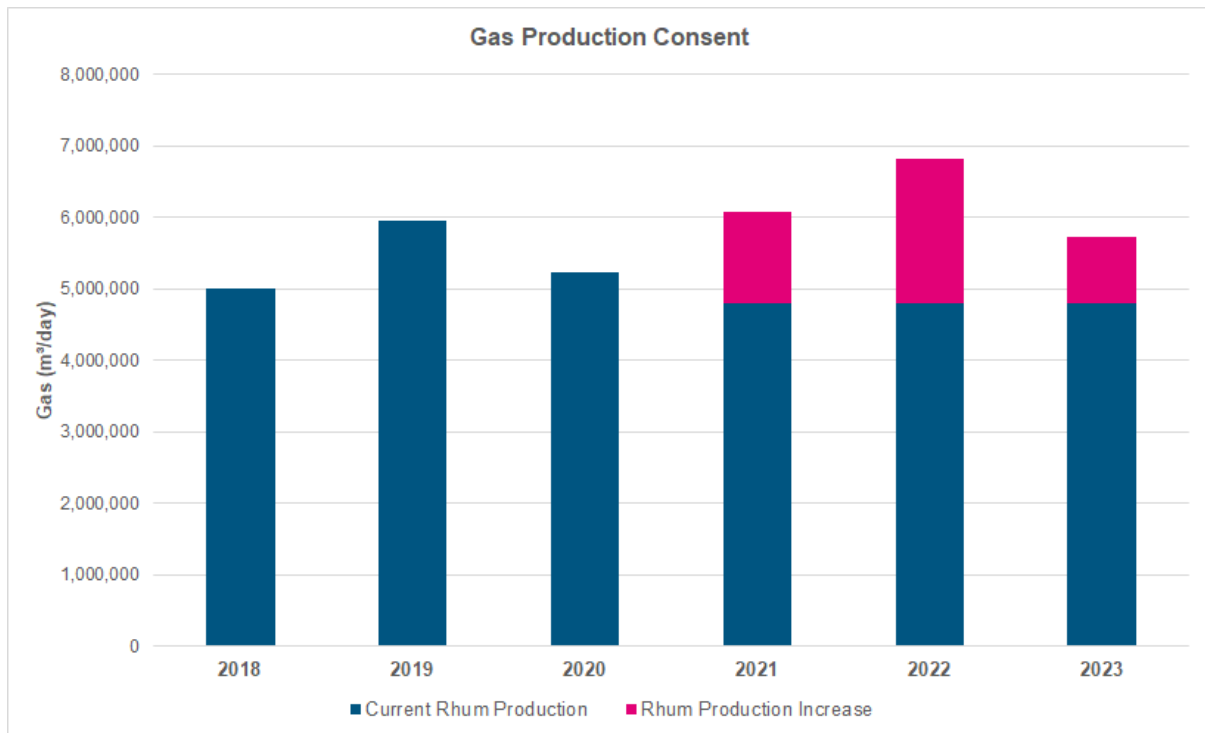

Figure 3 – Rhum field production forecasts 2018=2023

Table 4-2 - Rhum Production Increase

Year	Rhum			
	Baseline: Current maximum production consent (Gas) (m³/day)	Proposed maximum production consent (Gas) (m³/day)	Production Increase in m³ (Gas)	Percentage Increase
2018	5,012,000	-	-	-
2019	5,959,000	-	-	-
2020	5,235,000	-	-	-
2021	4,789,000	6,077,000	1,288,000	26.9
2022	4,118,000	6,824,000	2,706,000	65.7
2023	3,441,000	5,720,000	2,279,000	66.2
		Average Increase	2,091,000	-

## 5 Production Facility

The facilities on the Bruce platform are capable of handling the production and processing of gas/condensate and oil from the Bruce, Keith and Rhum fields and the export of the separated gas and oil/condensate to the onshore processing facilities at St. Fergus and Kinneil respectively. No plant modifications will be required for the increase in production from the Rhum field.

### 5.1 Process overview

No additional production equipment will be required to process the additional hydrocarbons from the Rhum R3 well.

The Bruce facilities have three primary first stages of separation:

- The CR Slugcatcher processes gas from the Western Area Development and Keith subsea tie-backs. The CR Slugcatcher is a horizontal 3-phase separator.
- HP Separators process gas from both the Bruce platform wells and the CR Slugcatcher. There are two HP Separators which are vertical 3-phase separators (currently operating in 2-phase mode)
- The Rhum Separator processes gas from the Rhum subsea tieback. The Rhum Separator is a vertical 3-phase separator. Gas is treated immediately after the Rhum Separator for H<sub>2</sub>S by scavenging

All liquids are routed from these vessels directly to LP Separation. Water is sent on for processing and oil is exported via a 24" pipeline to FPS via the Unity Platform.

Bruce has three stages of compression and gas dehydration facilities:

- LPBC – Low Pressure Booster Compressors
- MP – Mid Pressure Compression
- Export – Export Compressors
- Dehydration occurs between MP and Export compression stages.

There are two LPBC, two MP, and two Export Compressors available. Dehydration occurs through a single dehydration column operating a glycol regeneration process. Gas is exported via a 32" pipeline to St Fergus via the Frigg Pipeline system.

### 5.2 Produced water.

Separated water from the HP and LP separators is treated in the PW treatment system. Water is routed preferentially to the PW injection booster pump for injection back into the reservoir. Water, treated to acceptable standards in accordance with the approved Bruce Oil Pollution Prevention and Control (OPPC) permit from BEIS, can be routed overboard to the sea. Water injection requirements are also made up as required from treated seawater.

Produced water is preferentially disposed of down a designated PW reinjection (PWRI) well. In 2021 a CETCO Energy Services (CETCO) deoiler package was installed onboard the Bruce Platform to cover a period of prolonged PWRI system maintenance. It is estimated that the PWRI is online 80%. When the PWRI is offline PW is discharged overboard via the CETCO de-oiler package, which cleans PW to an average of 8-12 mg/l OIW.

### 5.3 Flaring

The HP and LP flare systems each have individual Knockout (KO) drums to remove liquids prior to gas being discharged to the respective flare. All vent lines going towards the HP and LP flare KO drums lines are sloped and without pockets. Gases discharged from the drums are routed separately via the platform's vertical flare tower to the respective flare tips (approximately 80m above the weather deck).

Flare Ignition Package M-13300 serves both the HP and LP flare systems. Utilities supplies from the instrument air, fuel gas and nitrogen systems are routed to the package to provide purging, pilot gas supplies and ignition facilities.

When necessary, flaring of gas from the dehydrators during start up is typically at 1.70 Mcm/d. Operational experience has shown that flaring during start-up is very rarely required. No additional flaring is expected as a result of the proposed increase in production.

### 5.4 Venting

On the Bruce platform, the atmospheric vents mainly dispose of gases vented from the hazardous open drains' caisson and glycol drains tank. There are also vent paths from the waste glycol tank and glycol regeneration skid. Liquids forming in the vent system, as a result of condensation, are removed via a drain leg formed from an enlarged, vertical section of piping incorporating a locked closed drain valve that discharges to the open hazardous drains. The drain leg is insulated, and trace heated to prevent freezing. The vent header is purged with nitrogen from two sources; blanketing gas from the glycol tanks and snuffing gas, injected at the base of the riser. The vent tip incorporates a bird screen and flame detectors which initiate alarms on the Platform Control System. As well as the main atmospheric vent, there are local atmospheric vents from atmospheric tanks. The vents are fitted with either bird cages or flame arrestors depending on the service. No additional venting is expected as a result of the proposed increase in production.

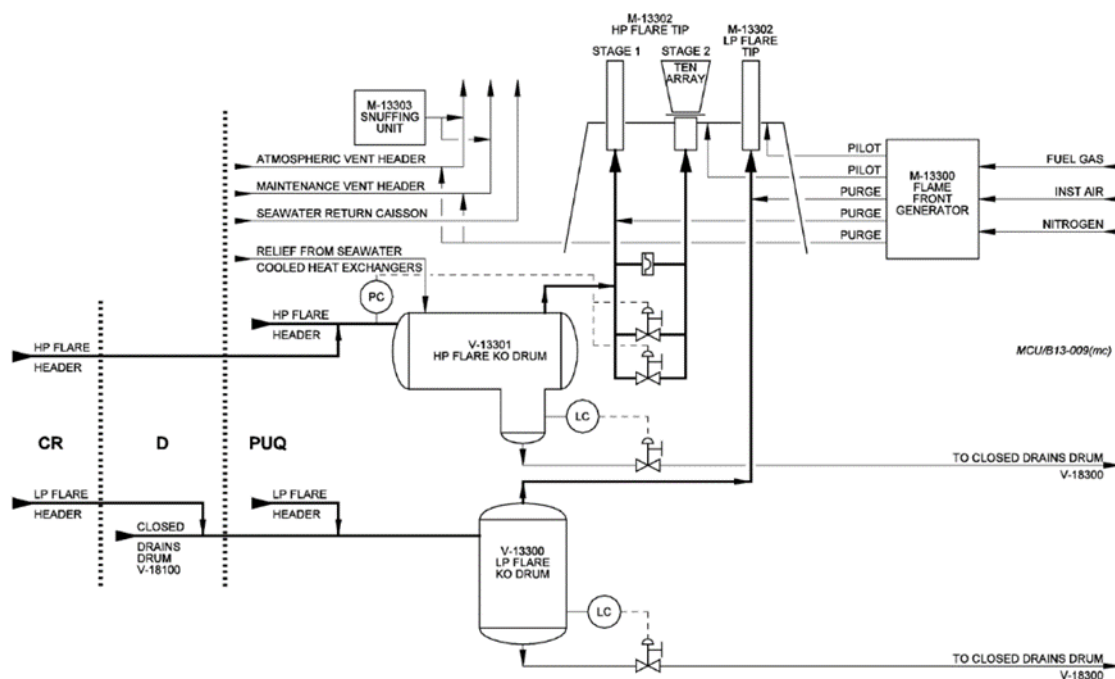

Figure 4 - Flaring and venting diagram Bruce Platform

## 5.5 Drains

Drainage at Bruce consists of three systems: open hazardous drains, open non-hazardous drains, and closed drains. The open drains system is segregated into the hazardous and non-hazardous open drains each with separate collection points. Please see Drainage Schematic of the arrangements on the Bruce Platform below.

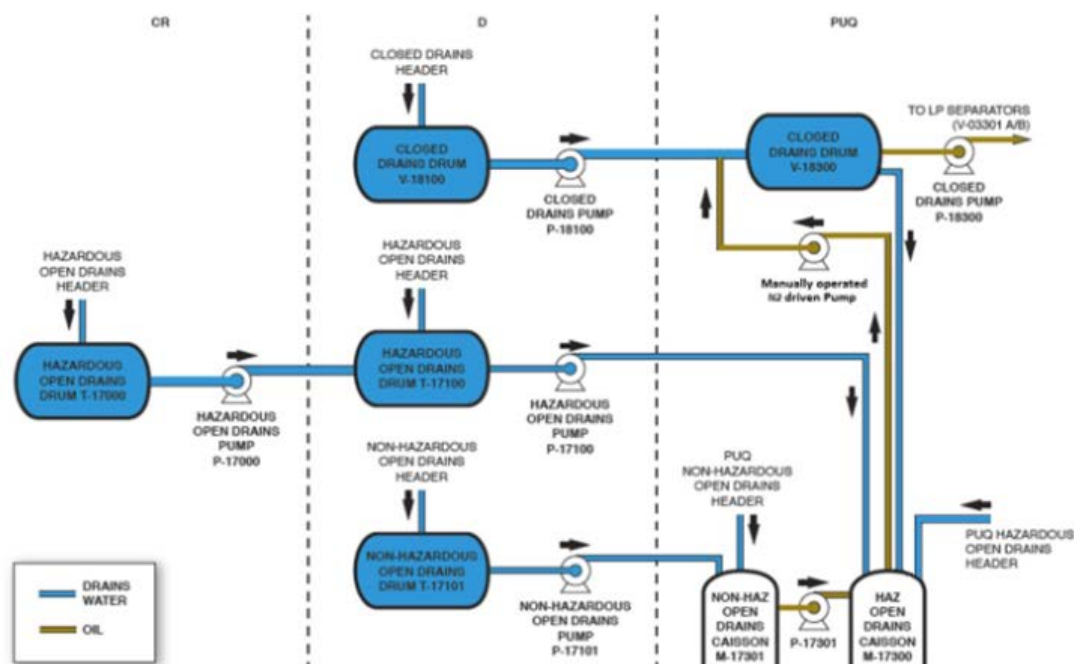

Figure 5 - Bruce Platform drains layout

## 5.6 Combustion equipment

The main combustion equipment at Bruce includes:

- Two Rolls-Royce RB211G gas-fired turbines to drive Medium Pressure / Export Gas compressors
- Two Rolls-Royce RB211C gas-fired turbines to drive electrical generators.
- Two Solar Mars 100 gas turbines to drive the LPBC trains.

The other combustion units forming the installation are all diesel powered engines. They drive crane engines (four in number), firewater pumps (three), emergency generators (two) and cement pumps for drilling (two). These engines are insignificant in terms of their size (power) and hours of use relative to the turbines. Over 95% of emissions from the platform are from the turbines.

The most significant pollutant to be emitted from the combustion installation is oxides of nitrogen (NO<sub>x</sub>). Sulphur dioxide (SO<sub>2</sub>) is emitted in negligible quantities due to the low levels of sulphur in the natural gas burnt. SEUK also uses Low Sulphur Diesel in all the plant on the platform. Emissions of carbon monoxide and unburnt hydrocarbons are controlled by ensuring complete combustion through rigorous process monitoring and maintenance.

No additional combustion equipment will be required for processing and distribution of the additional product.

## 6 Environmental Baseline

This section describes the baseline environmental setting of the proposed location of the Bruce platform and Rhum R3 well. In addition, it identifies those components of the physical, chemical and biological environments that might be sensitive to the potential impacts arising from the proposed production increase. An understanding of the environmental sensitivities at both the local and regional level informs the assessment of environmental risks and potential impacts associated with the proposed activity.

### 6.1 Data sources

The environmental description draws on a number of data sources including published papers on scientific research in the area, industry wide surveys (e.g. the OSEA3 programme) and site-specific investigations commissioned as part of the exploration and development processes. The following survey were carried out in the BKR area of operations:

- BP Bruce (UKCS Blocks 9/8a, 9/9a and 9/9b) Seabed Environmental Survey (ERT, 2001);
- Bruce Environmental Baseline Project (Gardline Surveys, 2012);
- Rhum Manifold ROV Survey (Global Marine Research, 2014); and
- Northern North Sea ROV Analysis, Bruce Field (Fugro, 2017).

The main environmental features of Block 9/8 and 9/9, in which the host installation (Bruce PUQ) is located, are detailed below. Also included is a brief description of Block 3/29 where the Rhum gas field is situated although minimal discharges occur from this tie-back and thus the environmental description provided for this location is brief.

### 6.2 Weather and Sea Conditions

Water depths throughout the NNS are variable with a general increase in depth from the west to the Norwegian Channel in the east. Most of the inflows to the North Sea converge in the Skagerrak and are modified and/or dominated by wind effects. The major flow consists of Atlantic water that follows the 200 m depth contour to the north of the Shetland Islands before passing south along the western edge of the Norwegian Trench (off the south and west coasts of Norway). Some of this water may, on occasion, pass south in the NNS close to the eastern border of the Shetland Islands.

Water currents in the NNS consist of two main components. A southward near surface residual flow in the Norwegian trench varies from between 0.15 and 0.3 m/s. A smaller flow follows the 100 m contour and enters the NNS between the Shetland and Orkney Islands as the Fair Isle inflow (Figure 7). This flow is an admixture of coastal and Atlantic water that crosses the NNS along the 100 m contour in a narrow band via the Dooley Current before entering the Skagerrak (southern tip of Norway). The resultant gyre (Svendsen *et al.* 1991) is topographically generated and is characterised by low-speed residual currents, typically 0.2 m/s towards the south. Semi-diurnal tidal currents are relatively weak in the offshore NNS, with maximum speed approximately 0.4 m/s (DTI, 2004) and are generally less than this, even at mean spring tide (Johnson *et al.* 1993). Tidal currents over the NNS, including the BKR area, are relatively weak at around 0.26 m/s (UKDMAP, 1998).



Annual prevailing winds in the area originate from a southerly direction. These occur predominantly from the southeast, but also from the south. Wind speeds ranging between 8.7 and 13.9 m/s (fresh to strong breeze) are most frequently recorded in the area of the NNS (UKDMAP, 1998).

Sea surface water temperatures range from 6.5°C in winter to 14°C in summer, while sea bottom temperatures range from 6.5°C in winter to 7°C in summer (UKDMAP, 1998).

### 6.3 Air Quality and Climate

Whilst air quality is not monitored routinely at offshore sites, estimated emissions are reported through the DECC EEMS process which provide some indication of inputs of air pollutants, and regular air quality monitoring is carried out by local authorities in coastal areas adjacent to each Regional Sea. The air quality of all local authority areas is generally within national standards set by the UK Government's Clean Air Strategy (DEFRA 2019), though several Air Quality Management Areas (AQMAs) have been declared to deal with problem areas. Industrialisation of the coast and inshore area adjacent to certain parts of the central North Sea has led to increased levels of pollutants in these areas which decrease further offshore, though oil and gas platforms, and associated offshore activities, provide numerous point sources of atmospheric pollution. Generally, emissions from all pollutants have decreased since the earliest year the data is available from (1970, 1980, 1990 and 2000, depending on pollutant) partly as a result of policies put in place to control certain emissions and a decline in the use of solid and liquid fuels in the domestic and power generation sectors (DEFRA 2019). The UK has signed up to a number of high profile international agreements to improve air quality, requiring reduction of 5 key pollutants by 2030 of between 16% (NH<sub>3</sub>) and 88% (SO<sub>2</sub>). The UK had also committed to achieving "Net Zero" CO<sub>2</sub> emissions by 2050, following a reduction of 44% in CO<sub>2</sub> emissions between 1990 and 2018 (Climate Change Committee website).

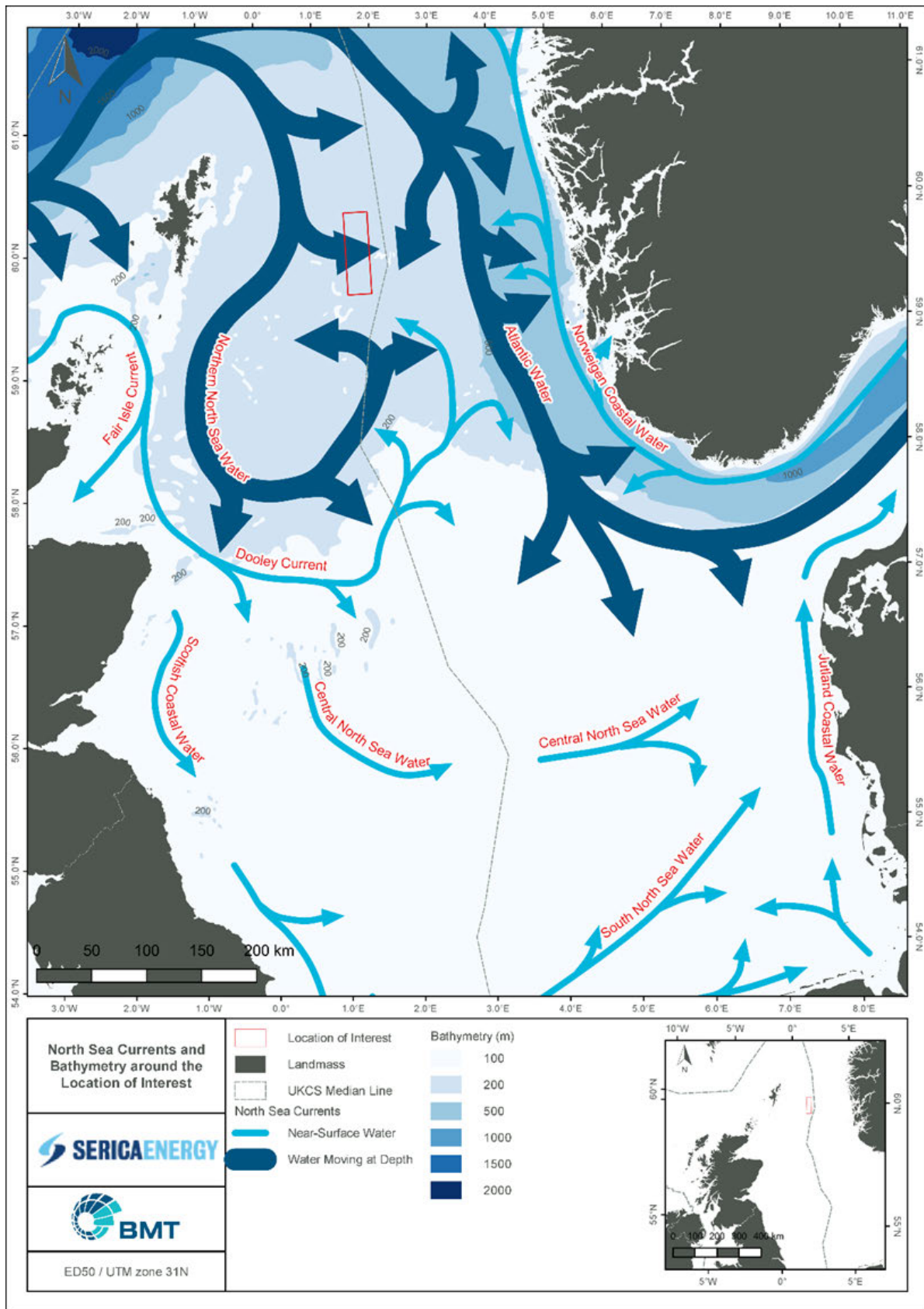

Figure 6 - North Sea currents and bathymetry

## 6.4 Seabed sediment

The nature of seabed sediments in this area of the North Sea results from a combination of hydraulic conditions, bathymetry and sediments supply. Sediments in the North Sea are comprised mostly of sand, gravel and muds in various proportions (MAFF, 1981; BGS, 1994). Sandy sediments occur within a wide range of water depths in the NNS, with significant regional variations in grain size, sorting and carbonate content (Johnson *et al.* 1993). Sediments to the east of Shetland are primarily sands in the shallower areas, becoming progressively muddier in the deeper water. In the NNS, large areas of sandy sediments are found north of 61°N, in water depths that range between 100 m to over 300 m. These sands are moderately to well sorted, and are mainly fine grained, with a carbonate content that ranges from 10 to 40%. In the NNS much of the sediment is fine and coarse sand (Kunitzer *et al.* 1992), constituting an approximate silt fraction of 5% and an organic fraction of 3% (Basford *et al.* 1993; Basford & Eleftheriou, 1988).

The Bruce Platform field lies in an area of sand, with areas of muddy sand to the north and southwest of the development (BMT Cordah, 1998; Figure 8). An environmental baseline survey was conducted by Gardline Environmental Ltd (Gardline) between September and October 2011. Samples were taken from 15 stations in the vicinity of the Bruce development in UKCS Blocks 9/8a, 9/9a and 9/9b. At the majority of the stations, fine sands with a fine (<63 µm, silt and clay) component and shell fragments was observed. The sand is underlain by areas of very soft to firm clay and medium dense to very dense clayey silty fine sand. Sediment sorting at all stations was poor, with the exception of Station 2011-BRU-REF-1 which was moderately sorted. Overall sediments were considered homogenous and representative of the fine sandy sediments of this area of the NNS (Gardline, 2012).

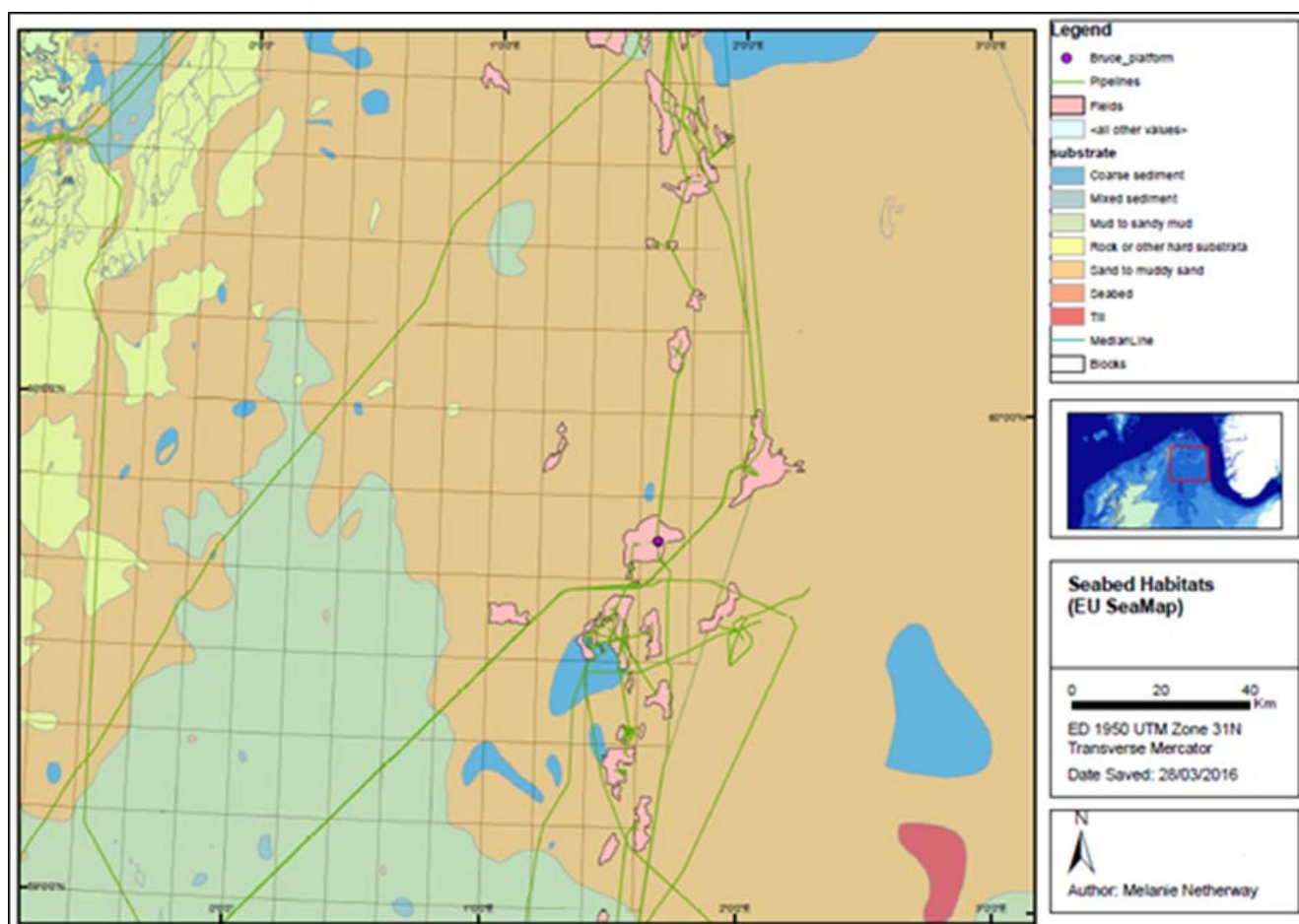

Figure 7 - Sediment in BKR area

## 6.5 Benthic communities

Numerous pre-and post-operational monitoring surveys have been carried out in the NNS. In 1993, it was found that benthic community structures were close to the ranges described by Kunitzer *et al.* in 1992. Densities ranged from 1,700 to 6,504 individuals per m<sup>2</sup>, and species richness ranged from 111 to 171 taxa (UKOOA, 2000).

The high species richness generally indicates sediments that are undisturbed and indicative of a stable environment. The most numerically dominant species identified were polychaete worms, especially two species of *Exogone*, *Aonides paucibranchiata*, *Glycera lapidum* and *Aricidea wassi*. Molluscs were the next most next abundant phylum, with the most numerous Molluscs including filter-feeding bivalves *Lima subauriculata* and *Thyasira sp.* The crustaceans were dominated by *Tmetonyx cicada*, *Synchelidium maculatum* and *Uncola planipes*. Sampling stations closed to platforms were dominated by opportunistic species indicative of organic enrichment. These species were polychaetes such as *Capitella capitata*, *Rhaphidrilus sp.*, *Paramphinome jeffreysii* and *Ophyrotrocha puerilis* (UKOOA, 2000).

The seabed survey conducted in the Bruce area in 2001 concluded that the composition of the macrofauna was representative of macrobenthic communities in the area of the North Sea where the survey took place (ERT, 2001). All sampling stations were dominated by the polychaete *Paramphinome jeffreysii*, and Polychaeta represented circa 50% of species

identified (ERT, 2001). There were indications of moderate modification in the benthic community close to the Bruce platform (most change was detected within 300 m of the platform), including reduced species diversity and increased abundance of individuals relative to background levels. Species indicative of an environment containing elevated hydrocarbon levels, including *Thyasira sarsi*, *Raricirrus beryli* and *Capitella capitata*, were found to be more abundant close to the Bruce platform (ERT, 2001). This change was attributed to successional change due to elevated levels of hydrocarbons and associated organic enrichment of the sediment around the Bruce platform (ERT, 2001).

The 2011 survey, conducted by Gardline Environmental Ltd. (Gardline) confirmed the findings of the 2001 survey. It was also noted in the 2011 survey that the polychaetes *Spiophanes bombyx*, *Galathowenia oculata* and *Minuspio cirrifera* together with juvenile echinoderms Ophiuroidea and Echinoidea dominated at most of the sample stations (Gardline, 2012). In terms of seabed contamination, hydrocarbon concentrations have decreased overall since the 2001 survey. This suggests that hydrocarbons in the sediments have continued to disperse and weather into the UCM (unresolved complex mixture) with little or no evidence of fresh hydrocarbon contamination into the sediment as a result of ongoing operations. Overall, the number of individual and taxa at all stations recorded in the Gardline 2011 survey was greater than recorded by ERT in the 2001 survey suggesting an increased species richness and diverse community. The results suggest that hydrocarbon and heavy metal contamination related to drilling discharges from the Bruce platform area have decreased across the survey area since 2001 (Gardline, 2012).

An ROV visual survey of the Bruce field was conducted more recently in 2015, (Fugro, 2017). Four subsea areas were sampled covering the Phase II WAD, the drilling platform, Bruce Subsea Isolation System and Bruce Control System. The substrate within the survey areas of the WAD manifold and Bruce Control System were characterised by fine sand and mud, subjected to bioturbation by burrowing macrofaunal including the Norway lobster (*Nephrops norvegicus*); whereas the areas surveyed surrounding the Bruce Drilling Platform and Bruce Subsea Isolation System were characterised as being comprised of mud and sand, with varying proportions of shells, shell fragments and gravel (Fugro, 2017). The presence of shells and gravel enabled the plumose anemone, *Metridium dianthus*, to settle in high numbers around the drilling platform, although the recorded abundance of this species in the area of the Subsea Isolation System was reduced in comparison (Fugro, 2017).

## 6.6 Plankton

The smaller zooplankton in the NNS is dominated by the copepod *Calanus finmarchicus* which occupies surface waters during summer and overwinters in the deep cold overflow water below 500 m. The krill species (mainly *Meganyctiphanes norvegica*) are the most abundant macrozooplankton species. Gelatinous zooplankton may also be abundant, particularly following phytoplankton blooms.

The planktonic community is potentially sensitive to oil and chemical discharges into the sea. Any impacts from offshore oil and gas operations are likely to be small compared with the natural variations. However, any decrease in the distribution and abundance of planktonic communities, which may result from discharges of e.g. biocides and oil, could result in secondary effects on higher organisms that depend on the plankton as a food source.

## 6.7 Fish and shellfish

The Bruce platform lies within ICES area 48F1, this overlaps with the spawning ground for haddock (*Melanogrammus aeglefinus*), Norway pout (*Trisopterus esmarkii*), saithe (*Pollachius virens*), whiting (*Merlangius merlangus*), cod (*Gadus morhua*) and sandeel. The platform also lies in nursery areas for whiting, blue whiting (*Micromesistius poutassou*), Atlantic mackerel (*Scomber scombus*), herring, sandeels, ling (*Molva molva*), anglerfish (*Lophius piscatorius*), haddock, Norway pout and also for European hake (*Merluccius merluccius*) (Coull *et al.* 1998 and Ellis *et al.* 2012). Of the 12-species listed above, two have been classified as being ‘vulnerable’ on the International Union for Conservation on Nature (IUCN) ‘Red List of Threatened Species’, cod and haddock, whereas a further six are listed as ‘least concern’, anglerfish, Atlantic mackerel, European hake, herring, Norway pout and whiting (IUCN, 2021). The remaining four species have not been evaluated. The data for fish are summarised in Table 3.

Analysis of the ROV footage and still images taken during the survey conducted by Fugro in 2015, identified cod, dab (*Limanda limanda*), haddock, ling, Norway pout, pollack (*Pollachius pollachius*), saithe and whiting within the Bruce field (Fugro, 2017). Both dab and pollack are listed as ‘least concern’ by the IUCN (2021).

In addition, a number of other fish species were identified from the ROV footage, including a ray species (*Rajidae* and *Raja spp.*), a catshark (*Scyliorhinidae*) and a red fish (*Sebastes*) spp., likely to be Norway haddock (*Sebastes viviparus*) given its distribution across much of the NNS; however, definitive identification to species level was not possible from the video analysis and therefore the conservation status cannot be ascertained for these species.

Table 5-1 - Fish Spawning and nursery at the Bruce Field

Species	J	F	M	A	M	J	J	A	S	O	N	D	Reference
Haddock (C)	N	S*/N	S*/N	S*/N	S/N	N	N	N	N	N	N	N	S: Spawning N: Nursery
Norway pout (C)	S/N	S*/N	S*/N	SN	N	N	N	N	N	N	N	N	C: Coull <i>et al.</i> 1998
Saithe (C)	S*	S*	S	S									E: Ellis <i>et al.</i> 2012
Whiting	C&E	S	S	S	S	S							* - high intensity
	E	N	N	N	N	N	N	N	N	N	N	N	
Cod (E)	S	S*	S*	S									
Sandeel (E)	S/N	S/N	N	N	N	N	N	N	N	N	S/N	S/N	
Blue Whiting (C&E)	N*	N*	N*	N*	N*	N*	N*	N*	N*	N*	N*	N*	
Mackerel (C&E)	N	N	N	N	N	N	N	N	N	N	N	N	
Herring (E)	N	N	N	N	N	N	N	N	N	N	N	N	
European hake (E)	N	N	N	N	N	N	N	N	N	N	N	N	
Ling (E)	N	N	N	N	N	N	N	N	N	N	N	N	

Species	J	F	M	A	M	J	J	A	S	O	N	D	Reference
Anglerfish (E)	N	N	N	N	N	N	N	N	N	N	N	N	

## 6.8 Marine mammals

Marine mammals include whales, dolphins and porpoises (cetaceans) and seals (pinnipeds). They may be vulnerable to the effects of oil and gas activities and can be impacted by noise, contaminants, oil spills and any effects on prey availability (SMRU, 2001). The abundance and availability of prey, including plankton and fish, can be of prime importance in determining the numbers and distribution of marine mammals and can also influence their reproductive success or failure. Changes in the availability of principal prey species may result in population level changes of marine mammals but it is currently not possible to predict the extent of any such changes (SMRU, 2001).

### 6.8.1 Cetaceans

All cetaceans are currently listed in Annex IV of the EC Habitats Directive (transposed as The Conservation of Habitats and Species (Amendment) (EU Exit) Regulations 2019) and are therefore classed as European Protected Species (EPS). EPS are protected regardless of their location under the Habitats Directive and it is an offence to deliberately disturb or physically injure any EPS.

Cetaceans regularly recorded in the North Sea include harbour porpoise (*Phocoena phocoena*), white-beaked dolphins (*Lagenorhynchus albirostris*), minke whales (*Balaenoptera acutorostrata*), Atlantic white-sided dolphins (*Lagenorhynchus acutus*), bottlenose dolphins, primarily in inshore waters, and killer whales (*Orcinus orca*) (Reid *et al.* 2003). Risso’s dolphins (*Grampus griseus*) and large baleen whales are also occasionally sighted. Spatially and temporally, harbour porpoise, white-beaked dolphins and minke whales are the most regularly sighted cetacean species in the NNS. Species recorded in the immediate vicinity of the Bruce field are minke whale, white-beaked dolphins and harbour porpoise, predominantly in the summer months around June and July and occasionally at the start of the year (UKDMAP, 1998). Other species sighted in the general area surrounding Block 9/9 are killer whale, and white-sided dolphins and long-finned pilot whale (*Globicephala melas*) (UKDMAP, 1998). The seasonal distributions of cetaceans in the vicinity of Bruce field, using data from the Atlas of Cetacean Distribution in North West European waters, are detailed in Table 4. All three species are currently listed as being ‘least critical’ on the IUCN ‘Red List of Threatened Species’ (IUCN, 2021).

Table 5-2 - Marine mammal densities in the area of the Bruce Platform (Reid *et al.*, 2003)

Species	J	F	M	A	M	J	J	A	S	O	N	D	
Harbour Porpoise		1				3	3					3	1: High Density 2: Moderate Density 3: Low Density Blank: No Data
Minke Whale			3										
White Beaked Dolphin			3			3							
Killer Whale			3										

## 6.8.2 Pinnipeds

Five species of seal have been identified in the North Sea: grey seal (*Halichoerus grypus*), common seal (*Phoca vitulina*), harp seal *Phoca groenlandica*, hooded seal *Cystophora cristata* and ringed seal *Pusa hispida*. However, only the grey and harbour seals live and breed in the UK (Jones *et al.* 2013; DECC, 2016).

Both grey and harbour seals are listed under Annex II of the EU Habitats Directive (transposed as The Conservation of Habitats and Species (Amendment) (EU Exit) Regulations 2019) and are PMFs. Approximately 38% of the world's grey seals breed in the UK and 88% of these breeds at colonies in Scotland with the main concentrations in the Outer Hebrides and in Orkney, while approximately 30% of harbour seals are found in the UK. However, this proportion has declined from approximately 40% in 2002 (SCOS, 2013). Seal tracking studies from the Moray Firth have indicated that the foraging movements of harbour seals are generally restricted to within a 40–50 km range of their haul-out sites (SCOS, 2013). The movements of grey seals can involve larger distances than those of the harbour seal, and trips of several hundred kilometres from one haul-out to another have been recorded (SMRU, 2001).

Since the Bruce field of operations is located approximately 155 km offshore (Figure 1), grey and harbour seals may be encountered from time to time, but it is not likely that they use the area with any regularity or in great numbers. This is confirmed by the latest grey and harbour seal density maps published by the Sea Mammal Research Unit (SMRU), supported by Jones *et al.* (2013), suggesting that the densities of both grey and harbour seals in the area of Bruce are fewer than 0.2 individuals per km<sup>2</sup>.

## 6.9 Seabirds

With the exception of vulnerability during oil spills or slicks, seabirds are not normally affected by offshore oil and gas operations on the UKCS. In the event of an oil spill, birds are vulnerable to oiling from surface oil pollution which could cause direct toxicity through ingestion and/or hypothermia as a result of the birds' inability to waterproof their feathers. The highest risks for potential hydrocarbon spillages are from: the loss of containment of transport and storage diesel fuel, incomplete oil/water separation and oil drop out from incomplete flaring.

Seabirds that may be found in the Bruce and Rhum area include northern fulmar (*Fulmarus glacialis*), northern gannet (*Morus bassanus*), Arctic skua (*Stercorarius parasiticus*), great skua (*Stercorarius skua*), black-legged kittiwake (*Rissa tridactyla*), little gull (*Larus minutus*), great black-backed gull (*Larus marinus*), common gull (*Larus canus*), lesser black-backed gull (*Larus fuscus*), herring gull (*Larus argentatus*), Sandwich tern (*Sterna sandvicensis*), common tern (*Sterna hirundo*), common guillemot (*Uria aalge*), razorbill (*Alca torda*), little auk (*Alle alle*) and Atlantic puffin (*Fratercula arctica*) (Kober *et al.*, 2010).

In general, seabirds feeding or resting on the sea surface are those most vulnerable to water borne pollution. The aerial habits of fulmar (*Fulmarus glacialis*) and gulls, together with their large populations and widespread distribution, reduce their vulnerability to oil related pollution. Auks (e.g. guillemot, razorbill and puffin) are the most vulnerable in the post-breeding season (July to August) when they become flightless during periods of moult, and thus spend large amounts of time in the water surface.

Generally, vulnerability is lowest during the pre-breeding and breeding months, increasing as the breeding season ends and birds disperse into offshore waters. The majority of seabirds



occurring on the UKCS are either included in Annex I (threatened bird species) of The Conservation of Habitats and Species (Amendment) (EU Exit) Regulations 2019, or are regularly occurring migratory species.

The Bruce Field is located in an area that has little data available within the new Seabird Oil Sensitivity Index dataset, however using the limited available data the area is conserved to be of low sensitivity throughout the year. The data regarding seabird sensitivity is summarised in Table 5.

Table 5-3 - Seabird oil sensitivity index (JNCC, 2019)

UKCS													
Block	J	F	M	A	M	J	J	A	S	O	N	D	
9/3	N	5	N	N	N	N	5	5	N	N	N	N	1: Extremely high
9/4	N	5	N	N	N	N	5	5	5	N	N	N	2: Very high
9/5	N	5	N	N	N	N	5	5	5	N	N	N	3: High
9/8	N	5	N	N	N	N	5	5	N	N	N	N	4: Medium
9/9	N	5	N	N	N	N	5	5	5	N	N	N	5: Low
9/10	N	5	N	N	N	N	5	5	5	N	N	N	N: No data
9/13	N	5	N	N	N	5	5	5	N	N	N	N	Using adjacent block sensitivity data as no data available for said block
9/14	N	5	N	N	N	5	5	5	N	N	N	N	
9/15	N	5	N	N	N	5	5	5	5	N	N	N	

## 7 Conservation Areas

### 7.1 Annex 1 Habitats

According to available data, there is one potential Annex I habitat, Fluid Seeps, in the vicinity of the Bruce field. The distribution of pockmarks in the UK North Sea is strongly correlated with that of the Witch Ground and Flags Formation sediments and the location of the Bruce complex is approximately 83 km north of the area most commonly associated with pockmark characteristics (i.e. the “Submarine structures made by leaking gases” located in the Braemar Pockmarks SAC). There are no SPAs, Special Areas of Conservation (SACs) or Sites of Community Importance (SCIs) in the vicinity of BKR area (Figure 1).

### 7.2 Annex II Species and European Protected Species

There are four marine mammal species listed under Annex II of the Habitats Directive which occur in relatively large numbers in UK offshore waters; grey seal, harbour seal, bottlenose dolphin and harbour porpoise. Of the Annex II species listed, harbour porpoise, harbour seal and grey seal may be present within the area. The harbour porpoise has been sighted in high densities in February and in low densities in June, July and December (UKDMAP 1998; Reid

*et al.* 2003), whereas the grey seal and harbour seal is found in low densities given the distance from the coast (Jones *et al.* 2003).

It is an offence to deliberately disturb any EPS as defined under Annexes I and IV of the Habitats Directive, or to capture, injure or kill an EPS at any time. Cetaceans are the only EPS likely to occur in the area.

### 7.3 Marine protected areas

There are no Nature Conservation Marine Protected Areas (NCMPA) in the BKR area. The closest is the Central Fladen which is located over 100 km to the southwest (Figure 1).

### 7.4 Social and Economic Environment

This section provides information on the broader social and economic considerations within the BKR area. For offshore oil and gas developments consideration is given to the potential impact on the fishing and shipping industries. In addition, the potential impact on other sea users, such as military organisations and the renewable energy sector.

#### 7.4.1 Fishing effort

Trawls were the prominent fishing gear type used in ICES Rectangle 48F1 in 2019, followed by seine nets, 442 and 53 (effort) days, respectively (Marine Scotland, 2020), consistent with demersal species accounting for 86% of landings. Total landings and value from the rectangle are shown in Table 6. The Bruce area of operations is not considered to be of particular commercial importance to the fishing industry and fishing effort for all species in this area is low in comparison with the remainder of the North Sea.

Table 7-1 - Annual fishing effort and landings recorded in the ICES AREA 48F1 (Marine Scotland, 2020)

Year	Landings (te)			Landings (£)			Effort (days)
2019	Total			Total			495
	2,370			4,090,149			
	D	P	S	D	P	S	
	2,027	338	5	3,952,426	120,233	17,490	
2018	Total			Total			485
	1,861			3,353,782			
	D	P	S	D	P	S	
	1,857	1	3	3,300,229	1,840	9,017	
2017	Total			Total			439
	1,946			3,353,782			
	D	P	S	D	P	S	

Year	Landings (te)			Landings (£)			Effort (days)
	1940	2	3	3,335,899	3,854	14,029	
2016	Total			Total			646
	4,491			5,226,890			
	D	P	S	D	P	S	
	2,572	1,917	2	3,943,736	1,275,598	7,556	
2015	Total			Total			529
	3,102			3,501,333			
	D	P	S	D	P	S	
	2,839	259	4	3,390,326	99,387	11,620	

D: Demersal; P: Pelagic; S: Shellfish

### 7.4.2 Oil and gas activities

There are a number of neighbouring installations and associated pipelines located within 40 km of the Bruce field; including (Figure 1):

- Beryl Bravo operated by Wood (approximately 17 km south, southwest);
- Beryl Alpha operated by Wood (approximately 26 km south, southwest);
- Frigg CDP1 operated by Total (approximately 26 km northeast);
- Kraken operated by EnQuest (approximately 30 km northwest);
- Heimdal operated by Equinor Energy AS (approximately 37 km southeast in Norwegian territorial waters); and
- Mariner operated by Equinor (approximately 39 km southwest).

Distances from the Bruce platform were checked using the marine Scotland MAPS NMPI (National Marine Plan interactive) tool (NMPI, 2021).

### 7.4.3 Shipping

Bruce is located in the vicinity of the route taken by vessels travelling between the Sullom Voe Terminal and Scandinavian ports. The shipping intensity in UKCS Blocks 9/8 and 9/9 (Keith and Rhum, respectively) is very low, whereas UKCS Block 3/29 (Rhum) experiences low shipping intensity (OGA, 2016).

#### 7.4.4 Other activities

There are no known: military activities; planned offshore renewable developments; aggregate activities; operational telecommunication cables; or wrecks within the immediate vicinity of the Bruce platform.

## 8 Assessment of Potential Impacts from Planned Activities

This section summarises the initial screening of the potential environmental impacts from the increased production with inclusion of the Rhum R3 well. Following the screening, further evaluation of the aspects which were not screened out is provided in this report. As can be seen in Table 8-1 below the majority of the potential impacts were screened out and those impacts carried forward for further assessment did not ultimately result in any significant impact.

### 8.1 Screening process

Screening includes consideration as to whether there will be any effects of the proposed change on the environment and are those effects potentially significant. From the outcome of this assessment further consideration is undertaken to determine their significance.

Table 8-1 - Screening Assessment

Aspect	Comments	Screening*
Environmental protection objectives	No UK environmental protection objects are assessed to be breached as a result of this request to increase production from the Rhum field.	X
Human health	As a result of the remote location of the Rhum field's producing asset, the Bruce Platform, no human health impacts are assessed to be associated with an increase in the Rhum fields productions.	X
Cultural heritage	No construction, installation or excavation of the seabed is planned therefore there is assessed to be no impact on cultural heritage (physical (artefacts) or social)	X
Use of natural resources	There is no construction or additional installation required.	X
Emissions	There is no change in emissions of waste or light expected to result from the proposed work.	X
	There is no increase in flaring or venting envisaged.	X
	Increased power generation (and resulting greenhouse gas emissions) is expected to slightly increase in 2022	Y
Marine discharge	Some increase in produced water will result, although use of the CETCO system and PWRI means that there will not be an increase in produced water discharge	Y
	A small increase in use and discharge of selected chemicals will be necessary	Y

Aspect	Comments	Screening*
Noise	There is no change in existing operations envisaged and no increase in, or addition to, noise emissions expected.	X
Seabed disturbance	No new subsea facilities will be installed and there will be no additional interaction with the seabed as a result of the proposed activities	X
Physical presence	There is no construction or additional installation required and so the physical presence of the field will not be increased. There is no additional vessel traffic to or from the field expected as a result of the proposed increase in production	X
Accidental event	An additional well will increase the chance of an accidental event (as the well was not previously flowing i.e., it was shut in and not capable of flowing). However, the worst-case magnitude of a spill will not increase from that previously assessed.	Y
Cumulative impacts	There will be a minor increase in greenhouse gas emissions in 2021. However, this increase will be temporary and very minor, and significant cumulative impacts are not expected	X

A brief assessment of the expected impacts on specific environmental receptors has also been included.

## 8.2 Atmospheric emissions

As production increases from the Rhum field there will be a slight increase in demand for fuel gas for the compression trains and to increase the capacity of the export compressor. Currently the export compressors run at a capacity of approximately 70-80% this will be increased to 90-100% once the increase in production on the Rhum field is realized.

As a result of this increased production fuel consumption levels are forecast to rise beyond previous estimates as a result of increased production from the Rhum field. This increase can be largely attributed to fuel gas consumption. The table below shows estimated fuel gas consumption for 2021 onwards compared to the previous 2019 baseline. 2020 has is not considered a suitable baseline as the plant was shut down for approximately 42 days as a result of emergency maintenance.

Table 8-2 - Fuel gas consumption at the Bruce Platform (2018-2024)

Year	Bruce Fuel Gas Consumption* (sm <sup>3</sup> )	% Increase on 2019 baseline
2019	99,585.764	Baseline Year
2020	84,627.465	-15.1%
2021	91,205.980	-8.5%
2022	102,278.030	2.7%
2023	88,714.770	-10.9%

\*Estimated Fuel Gas Consumption: Fuel Gas Consumption (Ave-2018/19/20) / Production volume x Forecast Production Volume.

As a result of the expected slight increase in fuel use, emissions of CO<sub>2</sub> and other greenhouse gases are likely to see a temporary increase on 2019 peak volumes.

Using 2019 figures as a baseline there is the potential to see a 2.7% increase in the emittance of greenhouse gases from the combustion of fuel gas in 2022 before a decline below baseline levels occurs from 2023 onwards. As such environmental impacts associate with this overall increase in combusted emissions are considered to be minor.

Table 8-3 - Emissions from fuel gas consumption at Bruce (2019-2024)

Year	Estimated Increase or decrease (%)	Total Emissions (te)						
		CO <sub>2</sub>	NO <sub>x</sub>	N <sub>2</sub> O	SO <sub>2</sub>	CO	CH <sub>4</sub>	VOCs
2019	Benchmark	214,404.70	554.9	18.31	4.04	500.69	75.03	4.72
2020	-15.1*	182,029.59	491.41	15.92	6.40	428.76	64.24	4.35
2021	-8.4	96,394.71	508.29	16.77	3.70	458.63	68.73	4.32
2022	+2.7	220,193.63	569.88	18.80	4.15	514.21	77.06	4.85
2023	-10.9	91,034.59	494.42	16.31	3.60	446.11	66.85	4.21

\*Plant shutdown for 42 days in 2020

It is not anticipated that bringing the Rhum R3 well online will increase overall flared volumes. The most significant flaring events from the Rhum field are associated with cold restarts. The length of the Rhum pipeline and the associated cooling in the line means that liquids are replaced with IMS gas hydrate inhibitor during periods of prolonged shut down, or when cyclical flaring is required during short term shut ins; Serica has gone a long way to significantly reduce flaring volumes from such flaring events in the last 2 years and the same best available techniques will continue to be implemented moving forward. Between 2019 and 2020 the Bruce Platform reduced flaring volumes by 4,613 tonnes to a total flared volume of 5,696 tonnes of gas (a substantial decrease even taking into consideration the 42 days of shutdown experienced at the plant). Bringing the Rhum wells back online is typically achieved with <100 tonnes of gas flared per event, and such events only occur up to 4 times in a year. It is not expected that any increase in either the frequency of flaring, or the volume of flaring will result from the increase in production from Rhum.

Energy production in the UK generated 95,800,000 tonnes of CO<sub>2</sub> in 2019 (BEIS, 2020). In 2022, proposed emissions at BKR will contribute 0.23% of this total, with the increase in emissions as a result of the proposed activities contributing a small fraction of this total (emissions from BKR contributed 0.22% of CO<sub>2</sub> emissions in 2019). The remote geographic location and winds within the offshore environment means that the atmospheric emissions would be rapidly dispersed and are not likely to be detectable within a short distance from the source.

Due to the remote geographic location and winds within the offshore environment, emissions are expected to rapidly disperse and are unlikely to be detectable within a short distance from the platform. No cumulative impacts with other activities in the area are expected.



In line with the UK's commitments to achieving its air quality and emissions targets (e.g. Net Zero), operations will be conducted as efficiently as possible to minimise emissions.

### 8.3 Discharges to sea

#### 8.3.1 Chemical discharges

The increase in gas production from the Rhum field is predicted to result in significant increase in use of H<sub>2</sub>S scavenger (+27%), demulsifier (+50%) and corrosion inhibitor (+69%), as well as smaller increases in use and discharge of biocide, oxygen scavenger and scale inhibitor (+1.5%). Other chemicals are injected based on liquid rates which are unaffected by the increases gas production. HSCV10610A and PHASETREAT 3701 will be discharged wholly or partly in PW, the discharge of which will be minimised due to use of the re-injection system. CORR10629A is not discharged. Additional environmental impact is expected to be minimal and will be assessed further in Chemical Permit SAT PRA/266 CP/1787.

Table 8-4 - Forecast increase in chemical usage (2021-2022)

Chemical	Current Use	Current + R3		Current + R3 2022 Max Forecast	
	Kg	Kg	% Increase	Kg	% Increase
H <sub>2</sub> S scavenger (HSCV10610A)	174,221	221,261	27%	247,394	42%
Demulsifier (PHASETREAT 3701)	3,186	4,769	50%	4,459	40%
Corrosion Inhibitor (CORR10629A)	3,186	5,400	69%	5,049	58%

#### 8.3.2 Hydrocarbon discharges

The increase in gas production from the Rhum field will increase daily produced water volumes by an estimated 36 m<sup>3</sup>/day. This increase accounts for an approximate 16% increase in overall PW volumes based on a current average daily total of 220 m<sup>3</sup>/day. As described in the Process Overview section PW is preferentially disposed of down a designated PW reinjection well. In 2021 a CETCO Energy Services (CETCO) deoiler package was installed onboard the Bruce platform to cover a period of prolonged PWRI system maintenance. It is estimated that the PWRI is online 80% of the time, with the remaining 20% assigned for essential maintenance works. When the PWRI is offline PW is discharged overboard via the CETCO de-oiler package at a concentration of between 8-12 mg/l. This PW management strategy demonstrates best available technology and techniques and significantly reduces the volume of oil discharged overboard. In 2019 a total of 0.53 tonnes of oil was discharged overboard in PW and this figure fell to 0.21 tonnes in 2020, following improved PWRI performance.

As of February 2021, all PW is being discharge via the CETCO de-oiler package due to ongoing maintenance on the PWRI system. PWRI is due to be back online approximately 4 weeks after the current estimate for start date of production from the R3 well. Once PWRI is

back online the volume of oil overboarded per annum will be reduced to an expected 0.15 tonnes despite the increased volume of produced water from the Rhum field.

Discharges into the marine environment will be rapidly diluted and dispersed in the marine environment. Consequently, the impact of the proposed increase in production from the Rhum field is not anticipated to have an impact on hydrocarbon discharges into the marine environment.

#### 8.4 Accidental releases

There will be no significant increase in oil or condensate production resulting from the proposed operations. Therefore, the modelled oil spill scenario, summarised below, remains valid.

Oil spill modelling has been conducted to predict and assess where oil spill impacts may occur for identified worst case scenarios in the Serica Offshore OPEP.

Two spill scenarios have been modelled in line with “Appendix B – Modelling Guidance of the UK OPEP Guidance<sup>12</sup>”. Four seasons were modelled: winter (Dec-Feb), spring (Mar-May), summer (Jun-Aug) and autumn (Sep-Nov) for all scenarios.

All modelled runs were given a full 28 days following cessation of release in order to fully examine the fate of the released hydrocarbons.

The assessed production increase in oil production from the Rhum field resulting from the bringing R3 online will not exceed the two currently modelled worst case scenarios. The maximum potential oil release volume 85 m<sup>3</sup> per day.

Table 8-5 - Possible worst case oil spill incidents

Scenario	Source	Oil Type	Volume (m <sup>3</sup> )	Type of Release
1	Worst case Loss of Well Control from Well 9/8a-B06	Crude	203 m <sup>3</sup> /day	Ongoing for 139 days
2	Instantaneous Pipeline Release (Midpoint of the Bruce to Forties Unity Pipeline - PL815)	Crude	59,600 m <sup>3</sup>	Instantaneous

Modelling has been carried out with the assumption that no intervention measures have been implemented after the release. This shows the maximum persistent impact of the worst case scenario spill of 203 m<sup>3</sup>/day, some 118 m<sup>3</sup>/day more than would be predicted from Rhum 3, the new well being brought online.



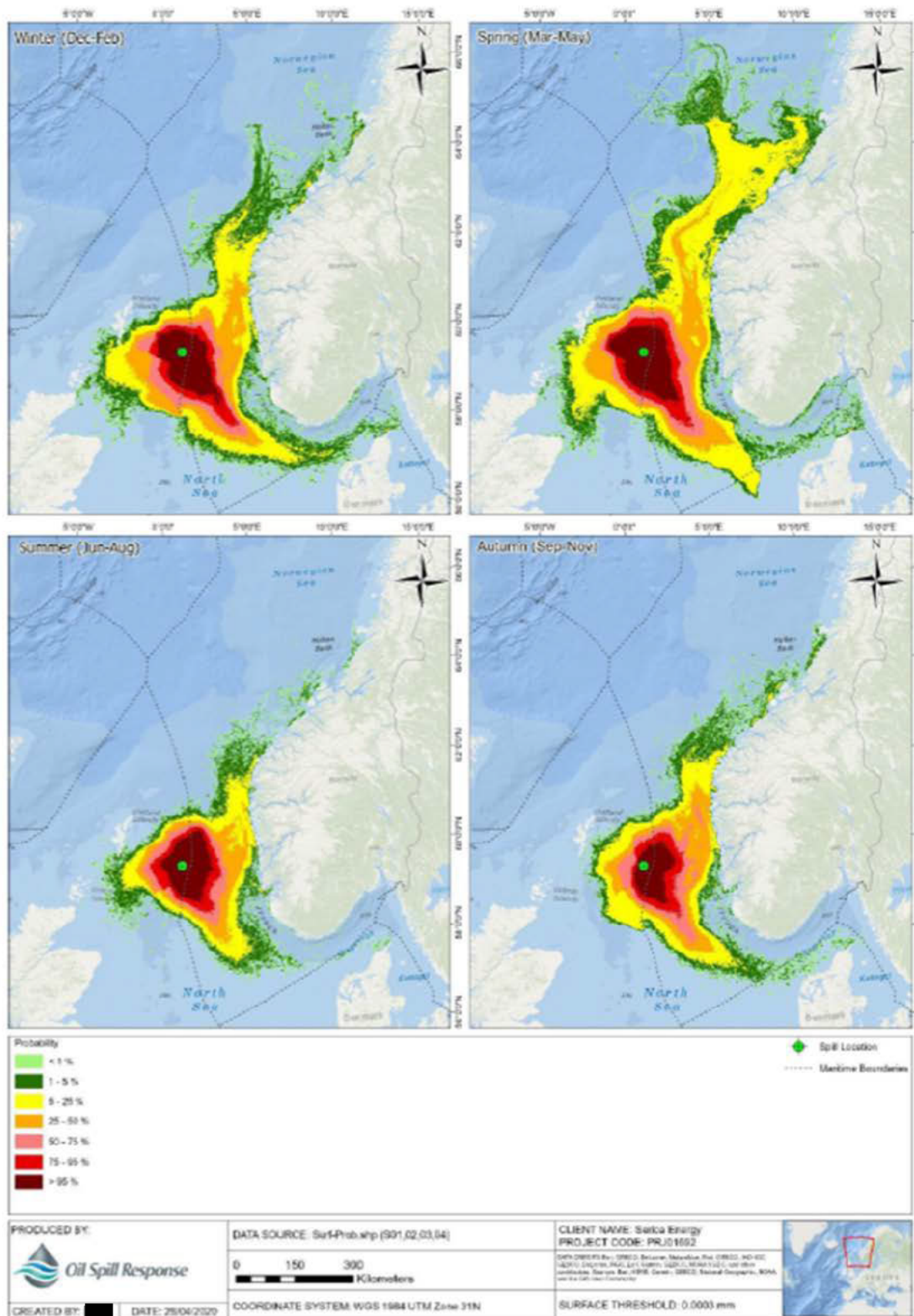

Figure 8 - Probability of oil contaminating the sea surface (based on thickness of 3µm)

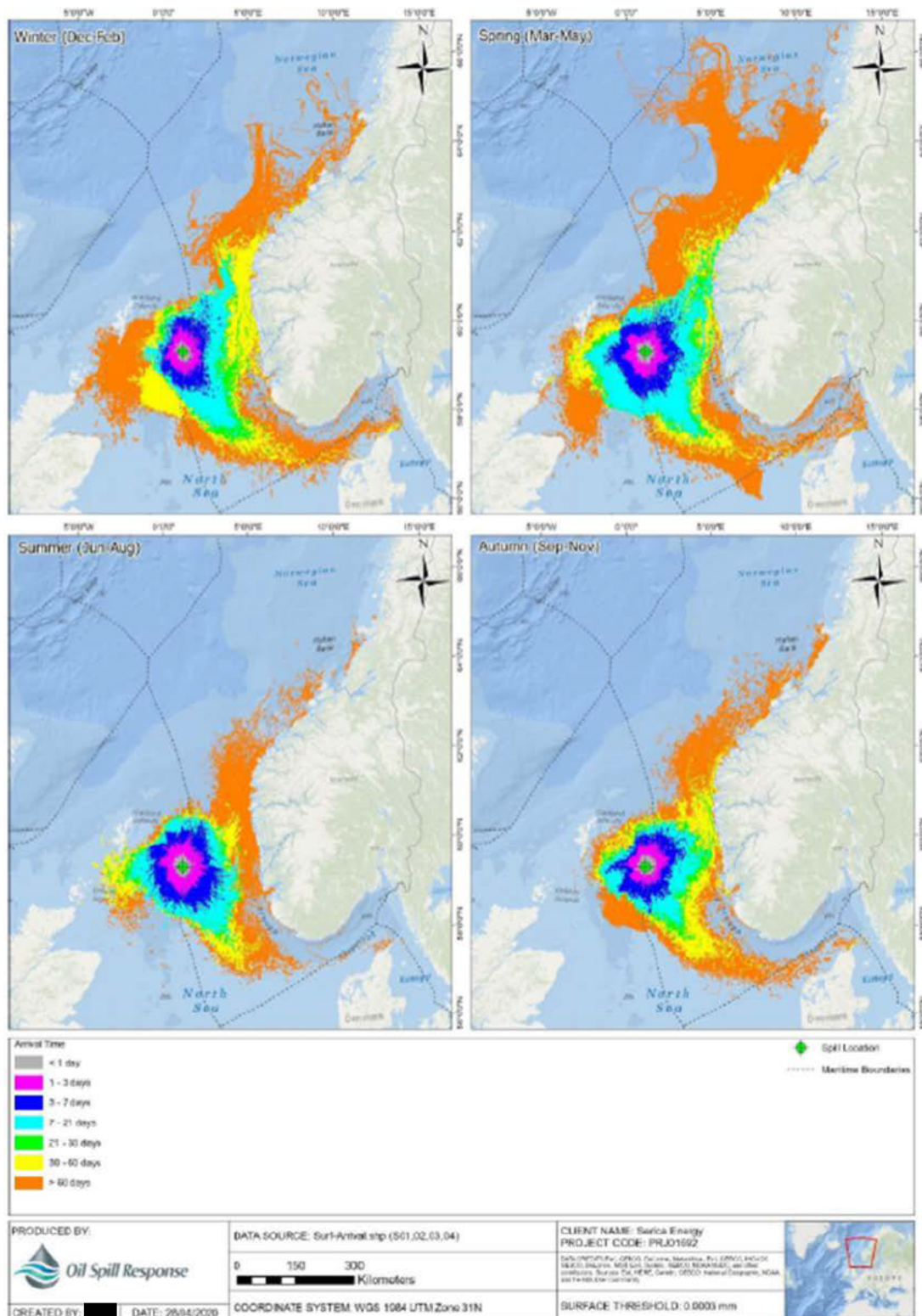

Figure 9 - Minimum time for oil to arrive at the sea surface (based on thickness 3µm)

## 8.5 Biodiversity

A summary of the impact assessment for the key biological features is provided below:

### 8.5.1 Plankton & Benthos

The plankton and benthic community is typical of those in the NNS and is not expected to be impacted by increased gas production. There will be no additional physical interaction with the seabed resulting from the proposed operations, and minor increases in chemical discharges are not expected to disturb the seabed or seabed communities. Discharges will be rapidly dispersed in strong water currents in the area.

### 8.5.2 Fish

The fish population in the area of operations as described is typical of that across the NNS. There will not be additional disturbance of the seabed as a result of the proposed operations, there will be no increased noise as a result of the proposed operations and increases in marine discharges are expected to be minimal. No additional disturbance to spawning or nursery areas is expected.

### 8.5.3 Seabirds

There is no additional increase in the risk of hydrocarbon spill resulting from the proposed operations. There will be no change in the physical presence of the facility and consequently no additional disturbance to migration routes or foraging behaviour caused by physical barriers or light pollution. As discussed above, significant impacts on prey species (fish) are not expected.

### 8.5.4 Marine mammals

There will not be additional disturbance of the seabed as a result of the proposed operations, there will be no increased noise as a result of the proposed operations and increases in marine discharges are expected to be minimal. There is no additional increase in the risk of hydrocarbon spill resulting from the proposed operations. There will be no change in the physical presence of the facility. As discussed above, significant impacts on prey species (fish) are not expected.

### 8.5.5 Protected sites and species

There are no designated protected sites within 40 km of Bruce platform operations, the nearest being the Braemar Pockmarks SAC, approximately 83 km south (Figure 1). There is no significant increase in risk of accidental release of hydrocarbon which may adversely impact protected habitats or species.

### 8.5.6 Other sea users

There will be no additional construction or installation of infrastructure, nor additional marine traffic resulting from the proposed activities and consequently other sea users are not expected to be adversely impacted.

## 8.6 Transboundary impacts

The level of increased emissions, hydrocarbon discharge and chemical usage and discharge from the increase in production from the Rhum field are not assessed to pose a significant environmental impact. The impacts are assessed to have limited if any significance outside of the immediate local area of the Bruce platform and the receptors within that area. Therefore, it has been concluded that operations will not result in any significant transboundary impacts.

In the event of a significant release to sea Serica has the necessary emergency response plans in place to facilitate Tier 1, 2 and 3 responses in a timely and decisive manner as demonstrated by numerous onshore and offshore oil spill response exercises. In the light of increased production from the Rhum field the two worst case response scenarios remain unchanged. The Bruce platform is located 17 km from the Norwegian median line (Figure 1) and in the event of release that was likely to cross this line the necessary notification process is captured in Serica Oil Pollution Emergency Plans.

## 9 National Marine Plan

The National Marine Plan (NMP) covers the management of both Scottish inshore waters (out to 12 nautical miles) and offshore waters (12 to 200 nautical miles). The aim of the NMP is to help ensure the sustainable development of the marine area through informing and guiding regulation, management, use and protection of the Marine Plan areas. Bruce operations as described in this permit have been assessed against the Marine Plan Objectives and policies, specifically GEN 1, 4, 5, 9, 12, 13, 14 and 21. BKR area operations do not contradict any of the marine plan objectives and policies. Serica will ensure they comply with all the new policies that have been introduced; with particular attention being made to the following policies:

### 9.1 GEN 1 – General planning and principle

Development and use of the marine area should be consistent with the Marine Plan, ensuring activities are undertaken in a sustainable manner that protects and enhances Scotland's natural and historic marine environment.

### 9.2 GEN 4 – Co-existence

Where conflict over space or resource exists or arises, marine planning should encourage initiatives between sectors to resolve conflict and take account of agreements where this is applicable.

### 9.3 GEN 5 – Climate change

Marine planners and decision makers should seek to facilitate a transition to a low carbon economy. They should consider ways to reduce emissions of carbon and other greenhouse gasses.

### 9.4 GEN 9 – Natural heritage

Development and use of the marine environment must:

This document is uncontrolled when printed or saved locally

- Comply with legal requirements for protected areas and protected species.
- Not result in significant impact on the national status of Priority Marine Features.
- Protect and, where appropriate, enhance the health of the marine area.

### **9.5 GEN 12 – Water quality and resource**

Developments and activities should not result in a deterioration of the quality of waters to which the Water Framework Directive, Marine Strategy Framework Directive or other related Directives apply.

### **9.6 GEN 13 – Noise**

Development and use in the marine environment should avoid significant adverse effects of man-made noise and vibration, especially on species sensitive to such effects.

### **9.7 GEN 14 – Air quality**

Development and use of the marine environment should not result in the deterioration of air quality and should not breach any statutory air quality limits. Some development and use may result in increased emissions to air, including particulate matter and gasses. Impacts on relevant statutory air quality limits must be taken into account and mitigation measures adopted, if necessary, to allow an activity to proceed within these limits.

### **9.8 GEN 21 – Cumulative impacts**

Cumulative impacts affecting the ecosystem of the Marine Plan area should be addressed in decision making and plan implementation.

## **10 Permits, licences and consents to be updated**

### **10.1 Production Consent**

This ES is to support an increase to the Rhum field Production Consent.

### **10.2 Chemical Permit**

There will be a requirement to update the following aspects of the permit:

- Chemical volumes.
- Production volumes.
- Produced water volumes.

### 10.3 Oil Discharge Permit

Changes to the production volumes will lead to an increase in annual PW volumes of approximately 36 m<sup>3</sup> per day. However, due to the introduction of the CETCO de-oiler package in 2021 and the PWRI system, this is not expected to translate into an increase in discharge. The Oil Discharge Permit will be varied to describe PW management as and when required.

### 10.4 Pollution Prevention and Controls Permit

The current PPC permit will not need to be varied and neither will the increased use of fuel gas alter Serica's compliance with the Large Combustion Plant NO<sub>x</sub> annual emissions limit. Despite the increase in production from the Rhum field Serica is confident that it will continue to operate within its currently permitted PPC emissions limits as a result of recent emissions reductions.

### 10.5 Flare and Vent Consents

Serica has reduced its flaring volumes significantly over the past two years and it is not expected that any variation to the Flare or Vent consent will be required as a result of the increase in production from the Rhum field. It is not anticipated that the Bruce platforms Vent Consent will be amended.

## 11 Conclusion

Gas production from the Rhum reservoir is expected to increase above ES thresholds stipulated in the EIA regulations due to the proposed workover of the R3 3/29a-6 production well. However since the well was drilled production estimates have fallen as a result of R3 being shut in. Flowing R3 for the first time and increasing overall production from the Rhum field will still see gas production rates remain below the 10.2 million m<sup>3</sup>/day peak estimate in the original Rhum Field Development Environmental Statement from 2002.

This ES has identified and assessed the potential environmental impacts associated with the production increase in line with the EIA Regulations (BEIS, 2020). Production and impacts, are expected to peak in 2022 and this ES assesses this year as the environmental worst case.

EIA screening was undertaken to identify potential impacts associated with the production increase. The following environmental aspects were assessed in further detail and it was concluded that the production increase will not result in a significant environmental impact.

**Atmospheric Emissions:** Fuel gas consumption and resulting emissions are expected to increase by 2.7% in 2022, from the previous peak in 2019 and will then decrease. Total peak estimated emissions were compared with total UK figures and considered to present a relatively small contribution (0.2% of total UK energy supply sector emissions). Furthermore, due to the remote geographic location and winds within the offshore environment, emissions are expected to rapidly disperse and are unlikely to be detectable within a short distance from the platform. No cumulative impacts with other activities in the area are expected.

**Marine Discharges:** The production increase will result in increased chemical requirements for production processing and increased PW volumes. However, use of the PWRI system will result in a net reduction in the volume of produced water discharged. OiW discharges from

the new wells represent a relatively minor contribution to overall volumes from the Bruce and Rhum fields and will be fully assessed in the Bruce Production Oil Discharge Permit . Chemical allowances associated with the production increase will be fully assessed in the Bruce Production Chemical Permit. This showed an increase in H<sub>2</sub>S scavenger, corrosion inhibitor and demulsifier. The permit will be reviewed and updated; accordingly. Discharges are expected to rapidly dilute and disperse within the strong water currents in the area and no significant impact from the additional discharge is expected.

**Accidental Events:** Bringing the previously drilled R3 well online increases the probability of a well release. However, the well flow rates are lower than other existing wells in the Rhum and Bruce fields and therefore the potential impact to the marine environment in the event of a release will not alter as a result of the increased production.

The project will adhere to all Serica Management Systems and relevant regulatory and legislative requirements. Serica therefore concludes that the production increase does not present a significant risk to the surrounding environment, including ecological receptors, protected sites and species, and other users of the sea.

## APPENDIX A – Non-Technical Summary

### Introduction and Description

The Bruce facilities are operated by Serica Energy (UK) Limited (hereinafter referred to as Serica), following divestment from Britoil Limited in Q4 2018. Located within the northern North Sea (NNS), the Bruce and adjacent Keith and Western Area fields lie in the United Kingdom Continental Shelf (UKCS) Blocks 9/8a, 9/9a and 9/9b in the North Sea in an approximate water depth of 122 m. The Rhum field is located in the northern North Sea (NNS) in block 3/29a, 400 km north east of Aberdeen and 44 km north of the Bruce Process, Utilities and Quarters (PUQ) platform (Figure 1). The Rhum gas field was brought online in 2005 and tied back to Bruce. This high pressure high temperature (HPHT) facility is situated in Block 3/29 at a water depth of 109 m.

Serica are conducting a workover the Rhum R3 3/29a-6 production well which was drilled as a high pressure, high temperature (HPHT) well by BP in 2005. The well forms part of the Rhum field development which consists of three subsea wells tied into a central manifold that produces back to the Serica operated Bruce Platform.

This Environmental Statement (ES) is in support an application to vary the current Production Consent volumes from the Rhum field for 2021 to 2024. The forecasted increase in production is a result of the following new well coming online in 2021; 3/29a-6 (known as Rhum R3).



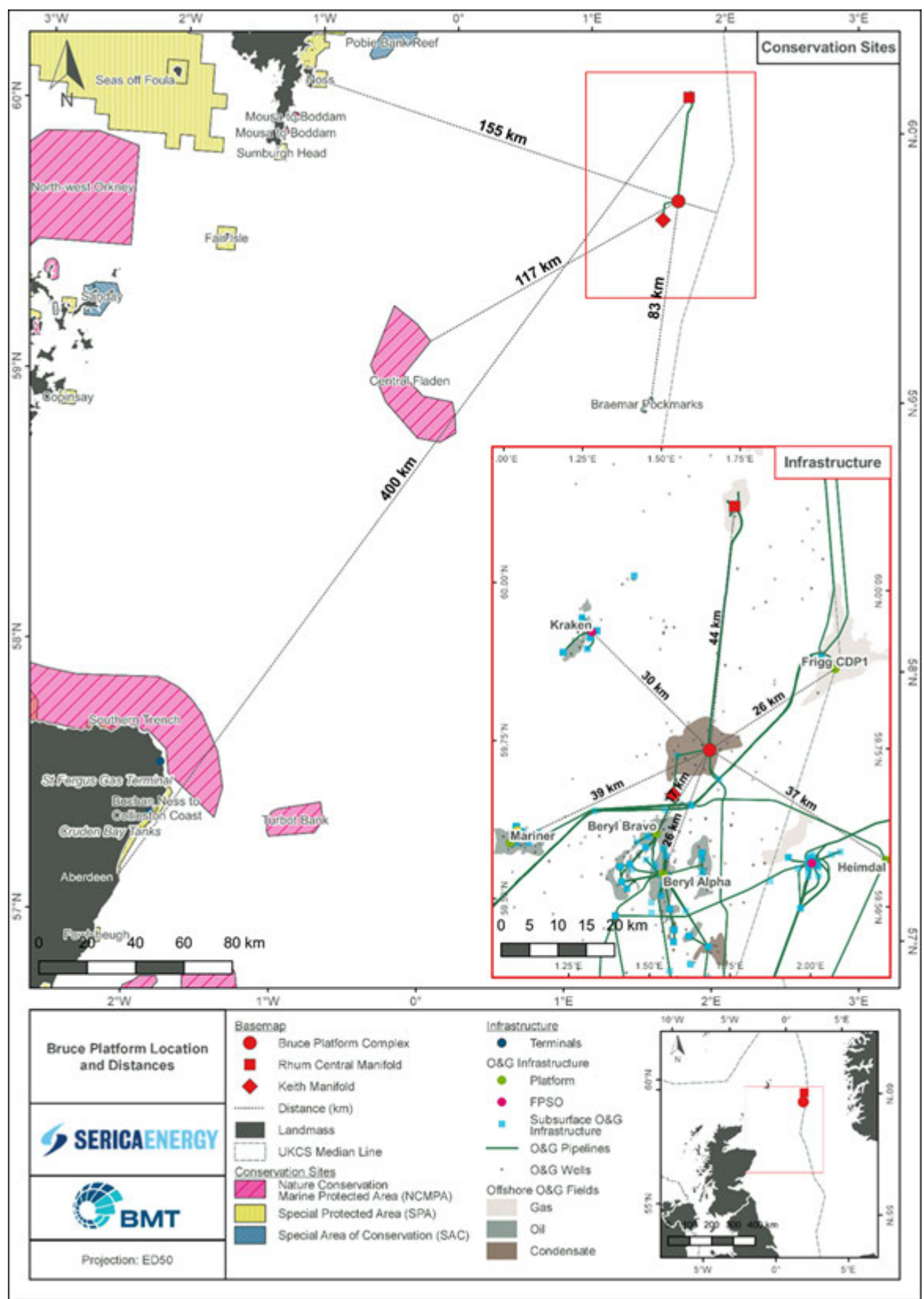

Figure 10 – Bruce, Keith and Rhum (BKR) Location Map

This document is uncontrolled when printed or saved locally



The Rhum field currently holds the following Petroleum Production Licences; P198, P566, P975. The current Long Term Production consent was granted to Serica Energy on 1<sup>st</sup> January 2018 and in its current form is due to expire on the 31<sup>st</sup> of December 2023. The production profile for the proposed increase from the Rhum field between 2021 and 2023 with the inclusion of the R3 3/29a-6 well is illustrated for the Rhum field in Figure 2. Post 2023 daily gas production volumes will fall below the 500,000 m<sup>3</sup> daily increase threshold returning to an assessed 4,865,000 m<sup>3</sup> per day, an increase of 76,000 m<sup>3</sup> on 2021 baseline maximum production estimates. The daily increase in Rhum field production will be in excess of 500,000 m<sup>3</sup> above the current consented production volume until 2024 with an average increase in annual production from the Rhum field assessed to be in the region of 2,091,000 m<sup>3</sup> per day.

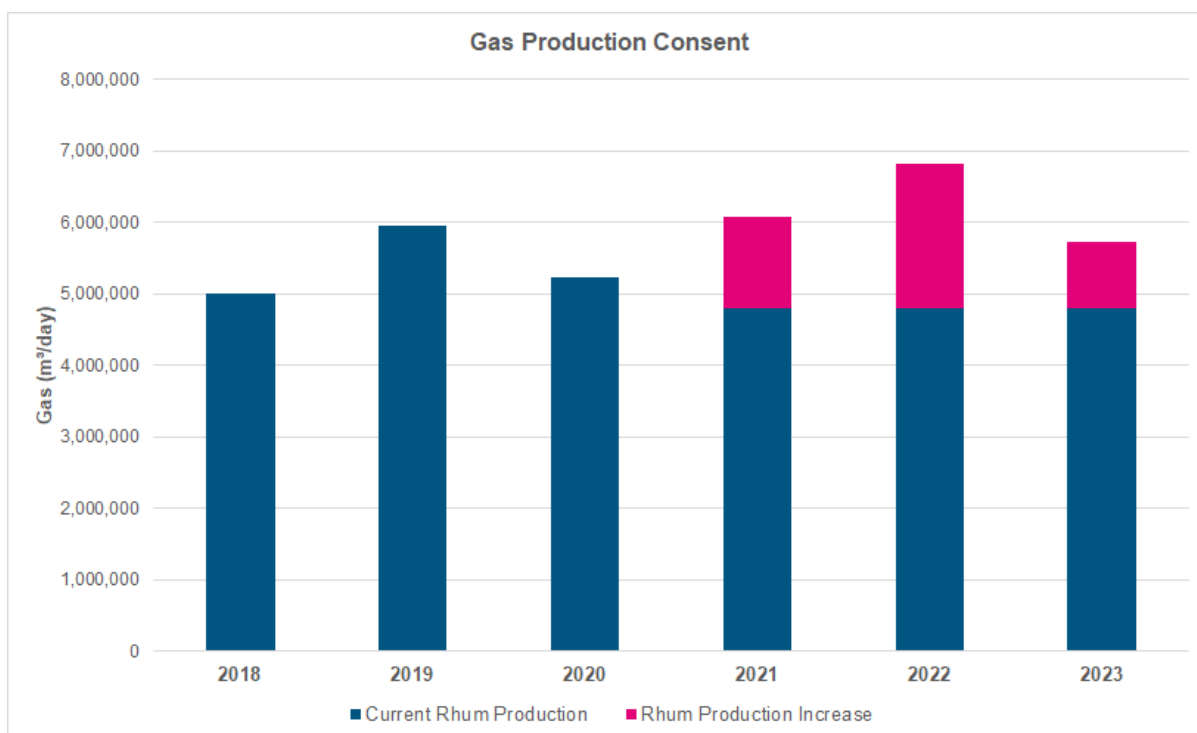

Figure 2 – Rhum field production forecasts 2018=2023

Table 1 - Rhum Production Increase

Year	Rhum			
	Baseline: Current maximum production consent (Gas) (m <sup>3</sup> /day)	Proposed maximum production consent (Gas) (m <sup>3</sup> /day)	Production Increase in m <sup>3</sup> (Gas)	Percentage Increase
2018	5,012,000	-	-	-
2019	5,959,000	-	-	-
2020	5,235,000	-	-	-
2021	4,789,000	6,077,000	1,288,000	26.9
2022	4,118,000	6,824,000	2,706,000	65.7
2023	3,441,000	5,720,000	2,279,000	66.2
		Average Increase	2,091,000	-

## Expected Potential Impacts

The proposed increase in gas production will not require additional infrastructure to be constructed or installed, and it will not require any change to the process or to combustion equipment, nor will it result in additional flaring or venting.

However, a small increase in fuel consumption and greenhouse gas emissions is expected. There will be an increase in the produced water. However, the recent installation of a de-oiler system which will operate at times when the produced water reinjection system (the primary mode of produced water disposal) is not in operation. Consequently, there it is not expected that the increase in produced water will translate into an increase in discharge of hydrocarbon.

## Environmental Baseline

The baseline around the Bruce, Keith and Rhum fields is typical of the northern North Sea.

### Physical Environment

Water depths throughout the NNS are variable with a general increase in depth from the west to the Norwegian Channel in the east. Water currents in the NNS consist of two main components. A southward near surface residual flow in the Norwegian trench varies from between 0.15 and 0.3 m/s. A smaller flow follows the 100 m contour and enters the NNS between the Shetland and Orkney Islands as the Fair Isle inflow. Annual prevailing winds in the area originate from a southerly direction. Sea surface water temperatures range from 6.5°C in winter to 14°C in summer, while sea bottom temperatures range from 6.5°C in winter to 7°C in summer (UKDMAP, 1998).

The Bruce Platform field lies in an area of sand, with areas of muddy sand to the north and southwest of the development (BMT Cordah, 1998). An environmental baseline survey was conducted by Gardline Environmental Ltd (Gardline) between September and October 2011.

This document is uncontrolled when printed or saved locally

Samples were taken from 15 stations in the vicinity of the Bruce development in UKCS Blocks 9/8a, 9/9a and 9/9b. At the majority of the stations, fine sands with a fine (<63 µm, silt and clay) component and shell fragments were observed. The sand is underlain by areas of very soft to firm clay and medium dense to very dense clayey silty fine sand. Sediment sorting at all stations was poor, with the expectation of Station 2011-BRU-REF-1 which was moderately sorted. Overall sediments were considered homogenous and representative of the fine sandy sediments of this area of the NNS (Gardline, 2012).

### Biological Environment

Seabed surveys conducted in the Bruce area indicate that the composition of the macrofauna was representative of macro benthic communities in that region of the North Sea. Communities are dominated by the polychaete *Paramphinome jeffreysii*, and Polychaeta represented circa 50% of species identified (ERT, 2001). Species indicative of an environment containing elevated hydrocarbon levels, including *Thyasira sarsi*, *Raricirrus beryli* and *Capitella capitata*, were found to be more abundant close to the Bruce platform (ERT, 2001). The polychaetes *Spiophanes bombyx*, *Galathowenia oculata* and *Minuspio cirrifera* together with juvenile echinoderms Ophiuroidea and Echinoidea dominated at most of the sample stations (Gardline, 2012). In terms of seabed contamination, hydrocarbon concentrations have decreased overall since the 2001 survey.

The Bruce platform lies within ICES area 48F1, this overlaps with the spawning ground for haddock, Norway pout, saithe, whiting, cod and sandeel. The platform also lies in nursery areas for whiting, blue whiting, Atlantic mackerel, herring, sandeels, ling, anglerfish, haddock, Norway pout and also for European hake (Coull *et al.* 1998 and Ellis *et al.* 2012). Of the 12-species listed above, two have been classified as being 'vulnerable' on the International Union for Conservation on Nature (IUCN) 'Red List of Threatened Species', cod and haddock, whereas a further six are listed as 'least concern', anglerfish, Atlantic mackerel, European hake, herring, Norway pout and whiting (IUCN, 2021). Marine mammals

Cetaceans regularly recorded in the North Sea include harbour porpoise, white-beaked dolphins, minke whales, Atlantic white-sided dolphins, bottlenose dolphins, primarily in inshore waters, and killer whales (Reid *et al.* 2003). Species recorded in the immediate vicinity of the Bruce field are minke whale, white-beaked dolphins, and harbour porpoise, predominantly in the summer months around June and July and occasionally at the start of the year (UKDMAP, 1998). Grey and harbour seals live and breed in the UK (Jones *et al.* 2013; DECC, 2016). Since the Bruce field of operations is located approximately 155 km offshore, grey and harbour seals may be encountered from time to time, but it is not likely that they use the area with any regularity or in great numbers.

Seabirds that may be found in the Bruce and Rhum area include northern fulmar (*Fulmarus glacialis*), northern gannet, Arctic skua, great skua, black-legged kittiwake, little gull, great black-backed gull, common gull, lesser black-backed gull, herring gull, Sandwich tern, common tern, common guillemot, razorbill, little auk and Atlantic puffin (Kober *et al.*, 2010).

### Protected areas and species

The Bruce complex is approximately 83 km north of the Braemar Pockmarks SAC). There are no SPAs, Special Areas of Conservation (SACs) or Sites of Community Importance (SCIs) in the vicinity of BKR area. The closest Nature Conservation Marine Protected Areas (NCMPA) is the Central Fladen which is located over 100 km to the southwest.

There are four marine mammal species listed under Annex II of the Habitats Directive which occur in relatively large numbers in UK offshore waters: grey seal, harbour seal, bottlenose dolphin and harbour porpoise. Of the Annex II species listed, harbour porpoise, harbour seal and grey seal may be present within the area.

### Human Environment (Other Users)

Trawls are the prominent fishing gear type used in the vicinity of the Bruce and Rhum fields ICES (Marine Scotland, 2020), consistent with demersal species accounting for 86% of landings. The Bruce area of operations is not considered to be of significant commercial importance to the fishing industry and fishing effort for all species in this area is low.

There are a number of neighbouring installations and associated pipelines located within 40 km of the Bruce field, with the closest being Beryl Bravo, 17 km to the south.

Bruce is located in the vicinity of the route taken by vessels travelling between the Sullom Voe Terminal and Scandinavian ports. The shipping intensity in UKCS Blocks 9/8 and 9/9 (Keith and Rhum, respectively) is very low, whereas UKCS Block 3/29 (Rhum) experiences low shipping intensity (OGA, 2016).

There are no known: military activities; planned offshore renewable developments; aggregate activities; operational telecommunication cables; or wrecks within the immediate vicinity of the Bruce platform.

### Assessment

A screening exercise, to consider whether there will be significant effects of the proposed change on the environment was carried out. As can be seen in Table 8-1 below the majority of the potential impacts were screened out and those impacts carried forward for further assessment did not ultimately result in any significant impacts.

Table 2 - Screening Assessment 1

Aspect	Comments	Screening*
Environmental protection objectives	No UK environmental protection objects are assessed to be breached as a result of this request to increase production from the Rhum field.	X
Human health	As a result of the remote location of the Rhum field's producing asset, the Bruce Platform, no human health impacts are assessed to be associated with an increase in the Rhum fields productions.	X
Cultural heritage	No construction, installation or excavation of the seabed is planned therefore there is assessed to be no impact on cultural heritage (physical (artefacts) or social)	X
Use of natural resources	There is no construction or additional installation required.	X
Emissions	There is no change in emissions of waste or light expected to result from the proposed work.	X

Aspect	Comments	Screening*
	There is no increase in flaring or venting envisaged.	X
	Increased power generation (and resulting greenhouse gas emissions) is expected to slightly increase in 2022	Y
Marine discharge	Some increase in produced water will result, although use of the CETCO system and PWRI means that there will not be an increase in produced water discharge	Y
	A small increase in use and discharge of selected chemicals will be necessary	Y
Noise	There is no change in existing operations envisaged and no increase in, or addition to, noise emissions expected.	X
Seabed disturbance	No new subsea facilities will be installed and there will be no additional interaction with the seabed as a result of the proposed activities	X
Physical presence	There is no construction or additional installation required and so the physical presence of the field will not be increased. There is no additional vessel traffic to or from the field expected as a result of the proposed increase in production	X
Accidental event	An additional well will increase the chance of an accidental event (as the well was not previously flowing i.e., it was shut in and not capable of flowing). However, the worst-case magnitude of a spill will not increase from that previously assessed.	Y
Cumulative impacts	There will be a minor increase in greenhouse gas emissions in 2021. However, this increase will be temporary and very minor, and significant cumulative impacts are not expected	X

Screening Table 1

### Atmospheric Emissions

As production increases from the Rhum field there will be a slight increase in demand for fuel gas for the compression trains and to increase the capacity of the export compressor. As a result of this increased production fuel consumption levels are forecast to rise beyond previous estimates as a result of increased production from the Rhum field. There is the potential to see a 2.7% increase in the emittance of greenhouse gases from the combustion of fuel gas and associated emissions of greenhouse gases in 2022 before a decline below baseline levels occurs from 2023 onwards. As such environmental impacts associate with this overall increase in combusted emissions are considered to be minor.

### Discharges to sea

The increase in gas production from the Rhum field is predicted to result in significant increase in use of H<sub>2</sub>S scavenger (+27%), demulsifier (+50%) and corrosion inhibitor (+69%), as well as smaller increases in use and discharge of biocide, oxygen scavenger and scale inhibitor (+1.5%). Other chemicals are injected based on liquid rates which are unaffected by the increases gas production. H<sub>2</sub>S scavenger and demulsifier will be discharged wholly or partly

in PW, the discharge of which will be minimised due to use of the re-injection system. The corrosion inhibitor will not be discharged. Additional environmental impact is expected to be minimal.

The increase in gas production from the Rhum field will increase daily produced water volumes by an estimated 36 m<sup>3</sup>/day. This increase accounts for an approximate 16% increase in overall PW volumes based on a current average daily total of 220 m<sup>3</sup>/day. However, produced water is preferentially disposed of down a designated PW reinjection well, while in 2021 a CETCO Energy Services (CETCO) deoiler package was installed onboard the Bruce platform to cover a period of prolonged PWRI system maintenance. A combination of these two techniques will result in a reduction in discharged produced water, to an expected 0.15 tonnes (from 0.53 tonnes in 2019 and 0.21 tonnes in 2020), and as such, no additional environmental impact is expected.

### Accidental Releases

There will be no significant increase in oil or condensate production resulting from the proposed operations. Therefore, the previously modelled oil spill scenario, remains valid.

### Conclusion

Gas production from the Rhum reservoir is expected to increase above ES thresholds stipulated in the EIA regulations due to the proposed workover of the R3 3/29a-6 production well.

This ES has identified and assessed the potential environmental impacts associated with the production increase in line with the EIA Regulations (BEIS, 2020). Production and impacts are expected to peak in 2022 and this ES assesses this year as the environmental worst case.

EIA screening was undertaken to identify potential impacts associated with the production increase. The following environmental aspects were assessed in further detail and it was concluded that the production increase will not result in a significant environmental impact.